

Description

The ZOPT2202 Sensor integrates two types of ultra-violet optical sensors: one that is primarily sensitive in the UVA spectral range and one that is sensitive in the UVB spectral range.

The device is connected via an I²C interface to a microcontroller. Other I²C or SMBus devices can be connected to the same interface. The device has a programmable interrupt with hysteresis to respond to events and reduce the microcontroller tasks.

A major application of the device is in smart phones or other mobile devices to enable UVA and UVB energy level measurements in support of diverse health care applications or contextual awareness algorithms.

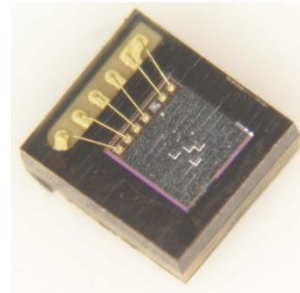

Features

- Very high sensitivity for UVA and UVB energy levels
- Superior visible light and infrared energy suppression
- Very stable spectral response over angle of light incidence
- Large dynamic range
- Excellent temperature compensation
- Lowest conversion repeat noise
- Parallel operation of UVA and UVB sensor
- I²C interface capable of standard mode (100kHz) or fast mode (400kHz) communication; 1.8V logic compatible
- Programmable interrupt function for UVA or UVB sensor with upper and lower thresholds

Sensor Features

- UVA/UVB sensor in a matrix array arrangement
- Configurable output resolution: 13 to 20 bits
- Configurable analog gain: ×1 to ×18
- Linear output code
- Fluorescent light flicker immunity

Physical Characteristics

- Wide operation temperature: - 40°C to +90°C
- Wide supply voltage: 1.7V to 3.6V
- Minimum active current at maximum duty cycle:
 - Single channel: 110µA typical
 - Dual channel: 130µA typical
 Note: Average current is proportionally lower with lower measurement rates.
- Low standby current: 1µA typical
- Packages:
 - LGA6 (2.0 × 2.2 × 0.7 mm)
 - TSV (1.1 × 1.2 × 0.26 mm)

ZOPT2202 Application Circuit

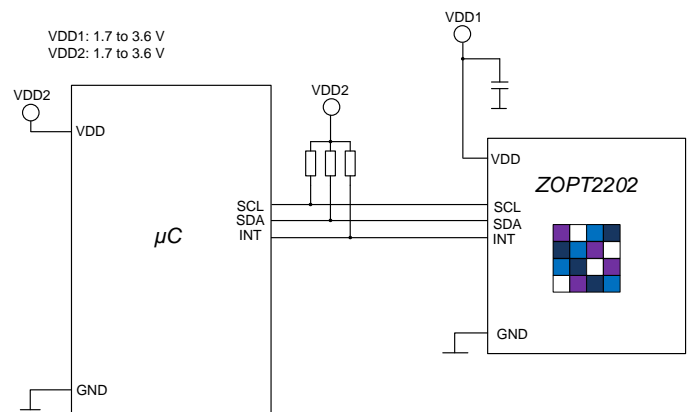

ZOPT2202 Block Diagram

- Applications**
- Cellular phones
 - Notebooks
 - Consumer devices

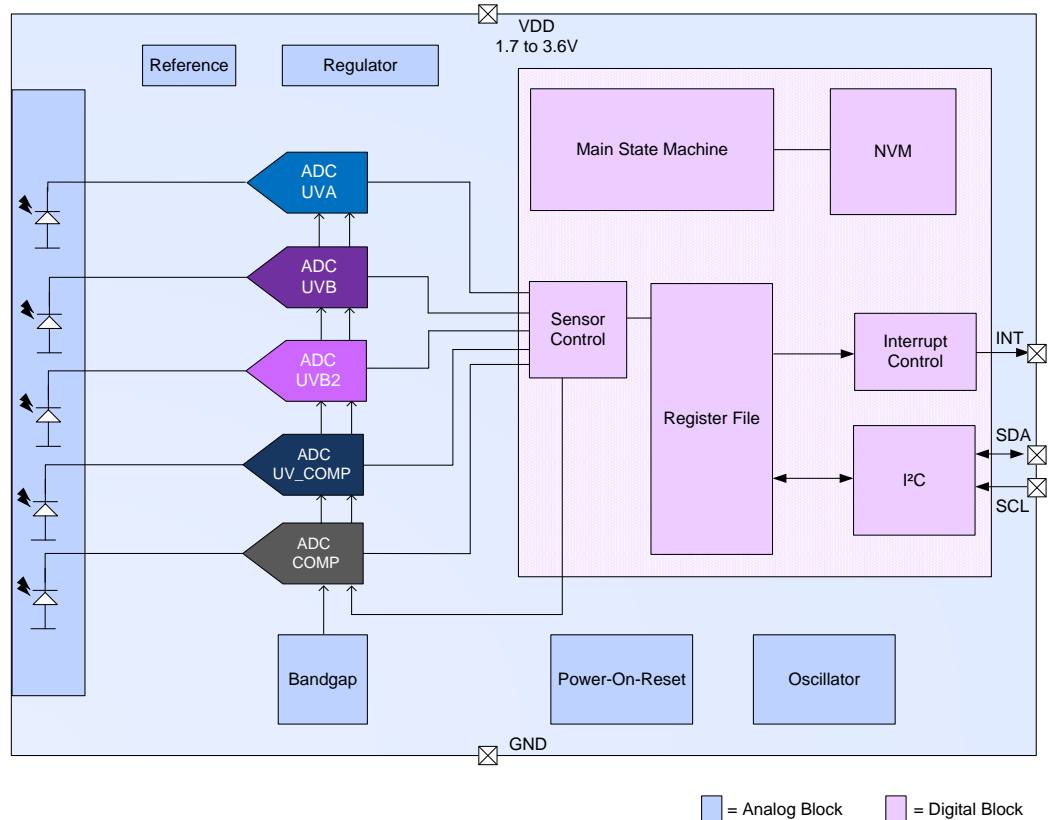

Ordering Information

Product Sales Code	Description	Package
ZOPT2202AC5R	ZOPT2202 LGA6 – Temperature range: -40 to +90°C	Reel
ZOPT2202AC9R	ZOPT2202 TSV – Temperature range: -40 to +90°C	Reel
ZOPT2202KIT V1.0	ZOPT2202 Evaluation Kit, including ZOPT Control Board, mini-USB cable, and 1 ZOPT2202 sample mounted on the LGA6 Sensor Board; kit software is available for free download – see the <i>ZOPT Evaluation Kit Quick Start-up Guide</i> included in the kit for instructions.	

Contents

1.	Characteristics.....	6
1.1	Absolute Maximum Ratings.....	6
1.2	Operating Conditions.....	6
1.3	Electrical and Optical Parameters.....	7
2.	Typical Device Parameters.....	9
3.	Detailed Description.....	12
3.1	Block Diagram of ZOPT2202.....	12
3.2	Application Circuit.....	13
3.3	Pin Description.....	14
3.4	Device Operation Modes.....	15
3.5	Conversion Control State Machine.....	17
3.5.1	Start Up after Power-On or Software Reset.....	17
3.6	UV Sensor Sensitivity Configuration.....	18
3.6.1	Analog Gain Modes, Resolution, and Measurement Time.....	18
3.7	Interrupt Features.....	19
3.8	I ² C Interface.....	20
3.8.1	I ² C Address Decoding.....	20
3.8.2	I ² C Register Read.....	20
3.8.3	Register Write.....	21
3.8.4	I ² C Interface—Bus Timing.....	22
3.9	Summary of Internal Registers.....	23
3.10	Detailed Description of Registers.....	24
3.10.1	MAIN_CTRL.....	24
3.10.2	LS_MEAS_RATE.....	25
3.10.3	LS_GAIN.....	26
3.10.4	PART_ID.....	27
3.10.5	MAIN_STATUS.....	27
3.10.6	UVB2_DATA.....	28
3.10.7	UVA_DATA.....	29
3.10.8	UVB_DATA.....	30
3.10.9	UV_COMP_DATA.....	31
3.10.10	COMP_DATA.....	32
3.10.11	INT_CFG.....	33
3.10.12	INT_PST.....	33
3.10.13	LS_THRES_UP.....	34
3.10.14	LS_THRES_LOW.....	34
3.10.15	LS_THRES_VAR.....	35
3.10.16	DEVICE_CONFIG.....	35

4. Packages.....	36
4.1 LGA6 Package (2.0 × 2.2 × 0.7 mm)	36
4.1.1 Mechanical Dimensions.....	36
4.1.2 Pin Assignment (Top View)	36
4.1.3 Reflow Profile	37
4.1.4 LGA Tape Packaging Information	38
4.2 TSV Package (1.1 × 1.2 × 0.26 mm)	39
4.2.1 Mechanical Dimensions.....	39
5. Part Order Information.....	40
6. Glossary	40
7. Document Revision History	41

List of Figures

Figure 2.1 UVAS Spectral Response – Linear	9
Figure 2.2 UVAS Spectral Response – Logarithmic	9
Figure 2.3 UVBS Spectral Response – Linear	9
Figure 2.4 UVBS Spectral Response – Logarithmic	9
Figure 2.5 UVAS Spectral Response vs. AOI	10
Figure 2.6 UVBS Spectral Response vs. AOI	10
Figure 2.7 UVAS Field of View (375nm LED)	10
Figure 2.8 UVAS Field of View (Polar) (375nm LED)	10
Figure 2.9 UVBS Field of View (310nm LED)	10
Figure 2.10 UVBS Field of View (Polar) (310nm LED)	10
Figure 2.11 Conversion Repeat Noise	11
Figure 2.12 Active Current vs. Supply Voltage	11
Figure 2.13 Normalized Active Current vs. Temperature	11
Figure 2.14 Standby Current vs. Temperature.....	11
Figure 3.1 Simplified ZOPT2202 Block Diagram	12
Figure 3.2 Typical Application Circuit.....	13
Figure 3.3 Main State Machine	17
Figure 3.4 Interrupt Unit	19
Figure 3.5 I ² C Register Read	21
Figure 3.6 I ² C Register Write	21
Figure 3.7 Bus Timing	22

List of Tables

Table 3.1	LGA Pin Description.....	14
Table 3.2	TSV Pin Description.....	14
Table 3.3	Mode Descriptions	15
Table 3.4	Channel Activation vs. Operation Mode.....	16
Table 3.5	UVAS Sensitivities	18
Table 3.6	UVBS Sensitivities	18
Table 3.7	Supported I ² C Clock Frequencies	20
Table 3.8	I ² C Address	20
Table 3.9	Bus Timing Characteristic	22
Table 3.10	Register Overview.....	23
Table 4.1	Reflow Profile Specifications.....	37

1. Characteristics

1.1 Absolute Maximum Ratings

The absolute maximum ratings are stress ratings only. The device might not function or be operable above the recommended operating conditions given in section 1.2. Stresses exceeding the absolute maximum ratings might damage the device. In addition, extended exposure to stresses above the recommended operating conditions might affect device reliability. IDT does not recommend designing to the "Absolute Maximum Ratings."

Parameter	Symbol	Conditions	Min.	Max.	Units
Maximum input supply voltage (VDD pin)	V_{DD-GND}			4.0	V
Maximum voltage on SCL, SDA and INT pins	V_{I2C}		-0.5	4.0	V
Maximum operating temperature range	T_{AMB_MAX}		-40	90	°C
Storage temperature	T_{STOR}		-45	95	°C
Maximum input current into any pin except supply pins (latch-up)	I_{IN}		-100	100	mA
Electrostatic Discharge Protection ^[a]	V_{HBM}	Human Body Model, JESD22-A114	2000		V

[a] HBM: C = 100pF charged to V_{HBM} with resistor R = 1.5kΩ in series; valid for all pins.

1.2 Operating Conditions

Parameter	Symbol	Conditions	Min.	Typ.	Max.	Units
Voltage supply on VDD pin	V_{DD}		1.7		3.6	V
Ambient operating temperature range	T_{AMB}		-40		90	°C

1.3 Electrical and Optical Parameters

$V_{DD} = 2.8V$, $T_{AMB} = -40^{\circ}C$ to $+90^{\circ}C$, unless otherwise noted.

Note: See important table notes at the end of the table.

Parameter	Symbol	Conditions	Min.	Typ.	Max.	Unit
Power On Reset						
DC power-on reset level	POR _{LH}	Slow variation of VDD	1.00	1.34	1.60	V
	POR _{HL}					
Current Consumption						
UVAB_S Mode ^[a]	I _{UVA}	Maximum duty cycle, VDD = 2.8V		110		μA
UVB_ONLY Mode ^[a]	I _{UVB}	Maximum duty cycle, VDD = 2.8V		100		μA
UVAB_Raw Mode ^[a]	I _{UVA+B}	Maximum duty cycle, VDD = 2.8V		130		μA
Standby Mode	I _{SBY}	ZOPT2202 in Standby Mode, no active I ² C communication		1	2	μA
I²C Interface						
I ² C signal input high	V _{I2Chigh}		1.5		VDD	V
I ² C signal input low	V _{I2Clow}		0		0.4	V
UVAS Characteristics						
Spectral response			See Figure 2.1 and Figure 2.2.			
Sensitivity at gain 1	G ₁	Specifications apply to the 20-bit resolution setting. Specifications change with resolution setting as given in Table 3.5.		0.106		$\frac{\mu W/cm^2}{count}$
Sensitivity at gain 3	G ₃			0.035		$\frac{\mu W/cm^2}{count}$
Sensitivity at gain 6 ^[b]	G ₆			0.018		$\frac{\mu W/cm^2}{count}$
Sensitivity at gain 9 ^[b]	G ₉			0.012		$\frac{\mu W/cm^2}{count}$
Sensitivity at gain 18 ^[b]	G ₁₈			0.006		$\frac{\mu W/cm^2}{count}$
Calibrated error at gain 18		Calibration done with UVA LED, 360nm, T _{AMB} = +25°C			10	%

Parameter	Symbol	Conditions	Min.	Typ.	Max.	Unit
UVBS Characteristics						
Spectral response			See Figure 2.3 and Figure 2.4.			
Sensitivity at gain 1	G ₁	Specifications apply to 20-bit resolution setting. Specifications change with resolution setting as given in Table 3.6		0.36		$\frac{\mu W/cm^2}{count}$
Sensitivity at gain 3	G ₃			0.12		$\frac{\mu W/cm^2}{count}$
Sensitivity at gain 6 [b]	G ₆			0.06		$\frac{\mu W/cm^2}{count}$
Sensitivity at gain 9 [b]	G ₉			0.04		$\frac{\mu W/cm^2}{count}$
Sensitivity at gain 18 [b]	G ₁₈			0.02		$\frac{\mu W/cm^2}{count}$
Calibrated error at gain 18		Calibration done with UVB LED, 310nm, T _{AMB} = +25°C			10	%
UVA / UVB Sensor Characteristics						
UVA / UVB sensor output resolution	UVS _{RES}	Programmable for 13, 16, 17, 18, 19, 20 Bit	13	18	20	Bit
UVA / UVB sensor dark level count	UVS _{DARK}	No illumination 20-bit resolution Gain range x18 T _{AMB} = -40 to +60°C		5	20	Count
Conversion Timing						
Minimum integration time [c]	t _{INTmin1}			3.125		ms
	t _{INTmin2}	With 50/60 Hz rejection		50		ms
Maximum integration time [c]	t _{INTmax}	With 50/60 Hz rejection		400		ms
Wake-up time from Standby Mode	t _{WAKE-STB}	From Standby to Active Mode (measurement can start)		500		μs
Measurement repeat rate [c]		Programmable	25		2000	ms
Timing accuracy [d]			-25		+25	%

[a] Maximum duty cycle is selected with a 100ms measurement time and 100ms repeat rate.

[b] Values valid up to 60°C.

[c] Typical timing accuracy applied.

[d] All specifications related to timing can vary by this value; for example, a repeat rate of 50ms could vary up to 62.5ms.

2. Typical Device Parameters

($V_{DD} = 2.8V$; ZOPT2202 configuration: 20-bit resolution and gain range x18; other settings at default unless otherwise noted.)

Figure 2.1 UVAS Spectral Response – Linear

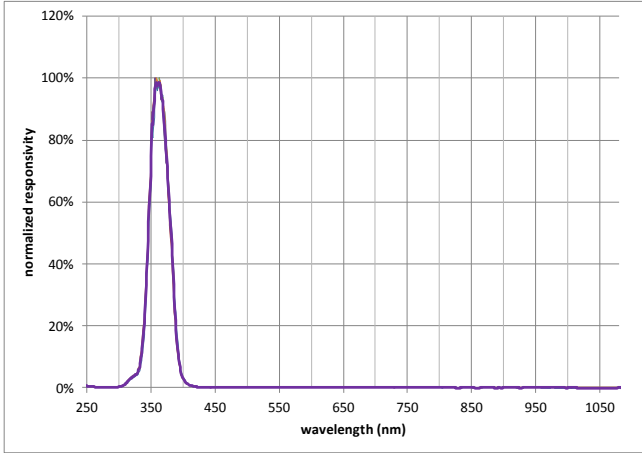

Figure 2.2 UVAS Spectral Response – Logarithmic

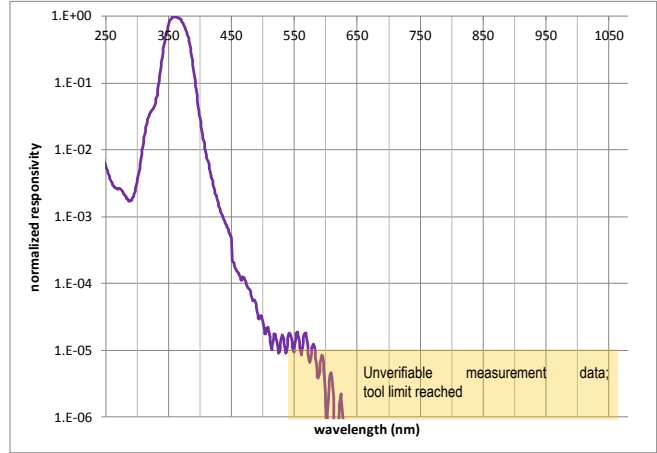

Figure 2.3 UVBS Spectral Response – Linear

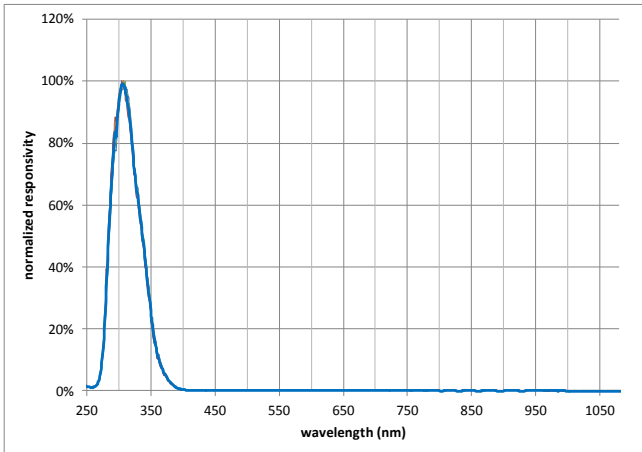

Figure 2.4 UVBS Spectral Response – Logarithmic

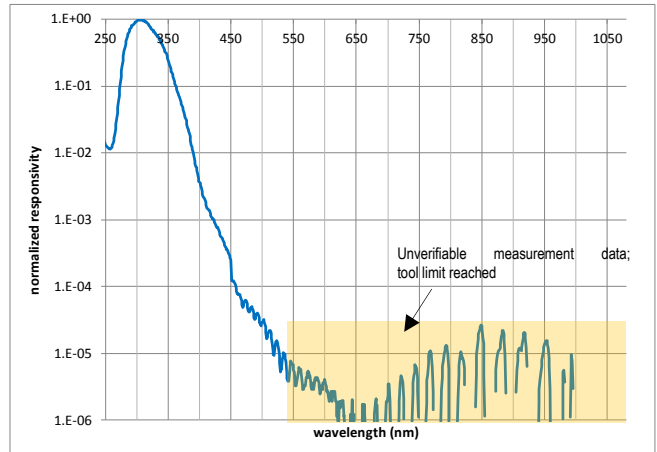

Figure 2.5 UVAS Spectral Response vs. AOI

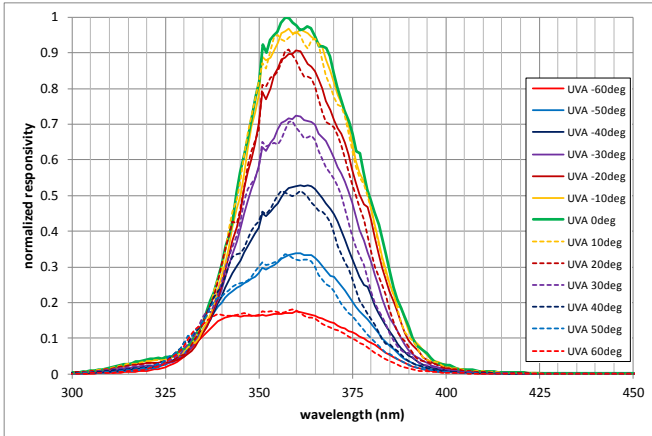

Figure 2.6 UVBS Spectral Response vs. AOI

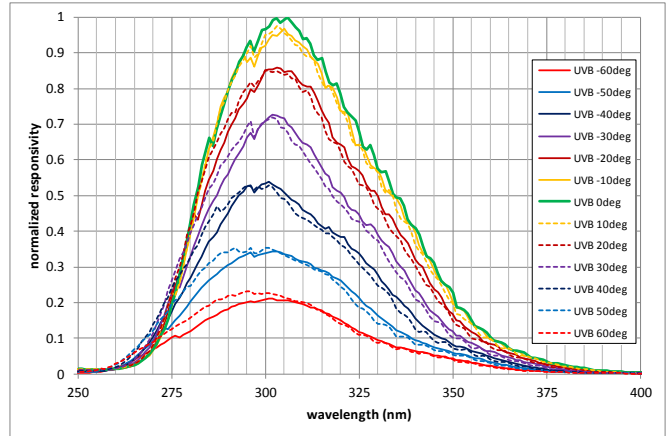

Figure 2.7 UVAS Field of View (375nm LED)

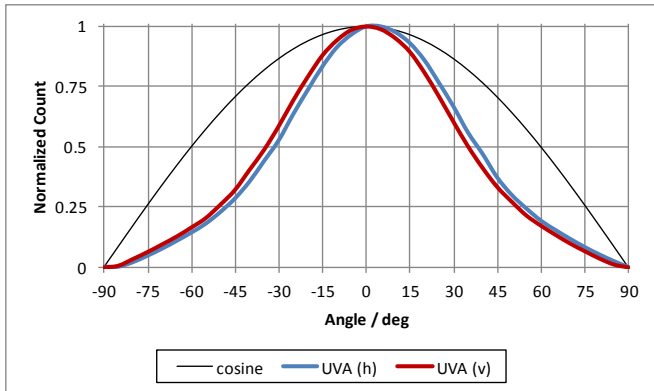

Figure 2.8 UVAS Field of View (Polar) (375nm LED)

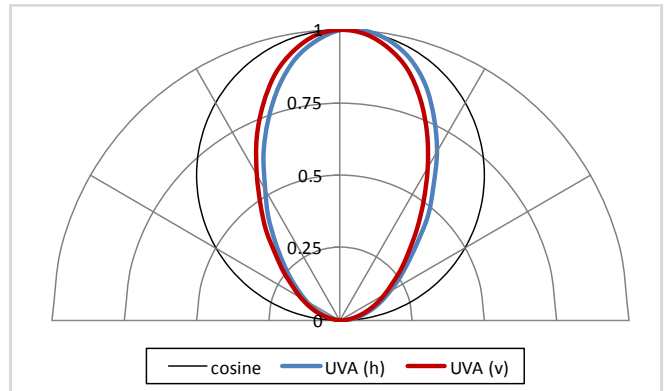

Figure 2.9 UVBS Field of View (310nm LED)

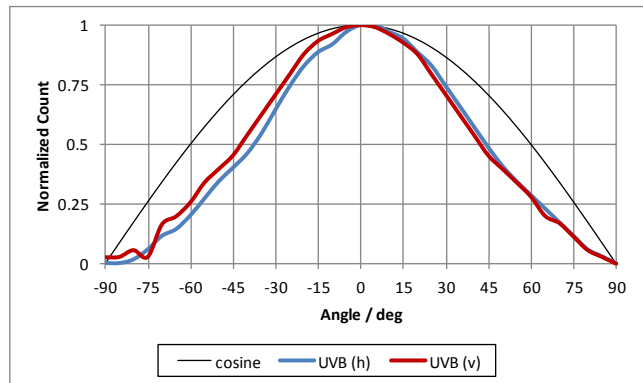

Figure 2.10 UVBS Field of View (Polar) (310nm LED)

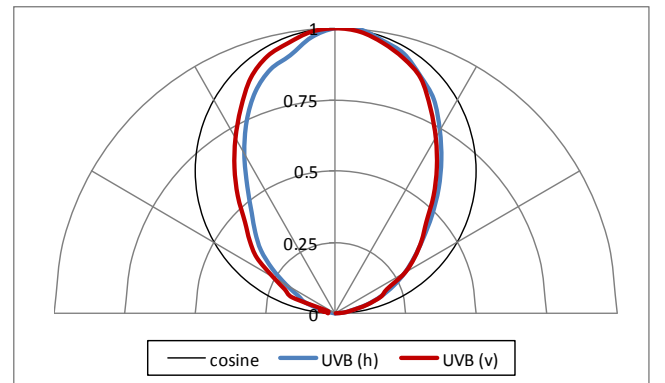

Figure 2.11 Conversion Repeat Noise

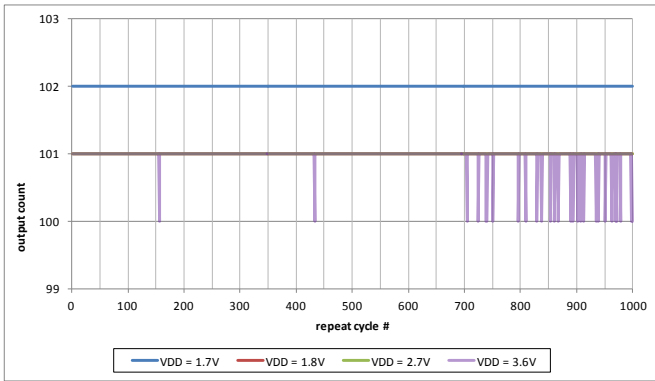

Figure 2.12 Active Current vs. Supply Voltage

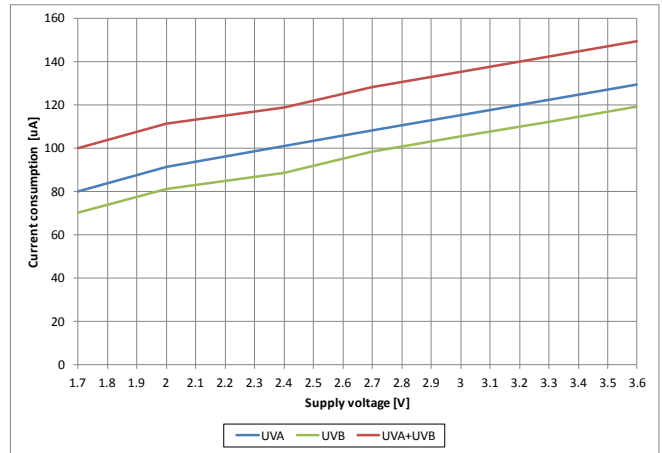

Figure 2.13 Normalized Active Current vs. Temperature

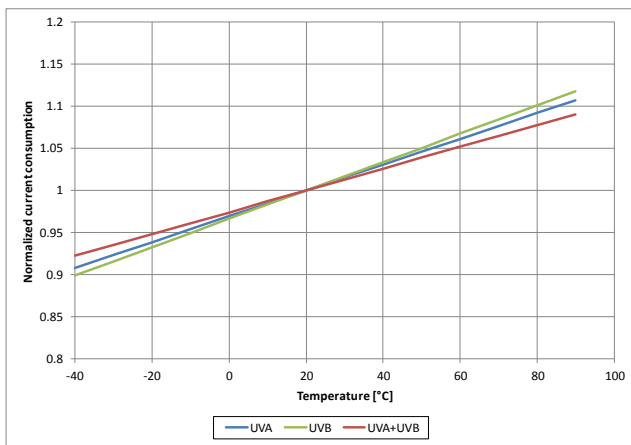
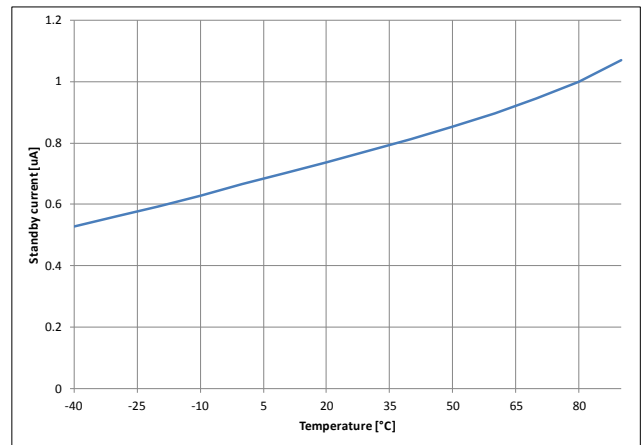

Figure 2.14 Standby Current vs. Temperature



3. Detailed Description

The ZOPT2202 contains 5 different photodiode channels for UV energy level measurement, temperature compensation, and stray light compensation. The sensor diodes are arranged in a matrix array. The photodiode currents are converted to digital values by the ADCs. The ZOPT2202 includes some peripheral circuits such as internal oscillator, current source, voltage reference, and non-volatile memory (NVM) to store trimming information.

3.1 Block Diagram of ZOPT2202

Figure 3.1 Simplified ZOPT2202 Block Diagram

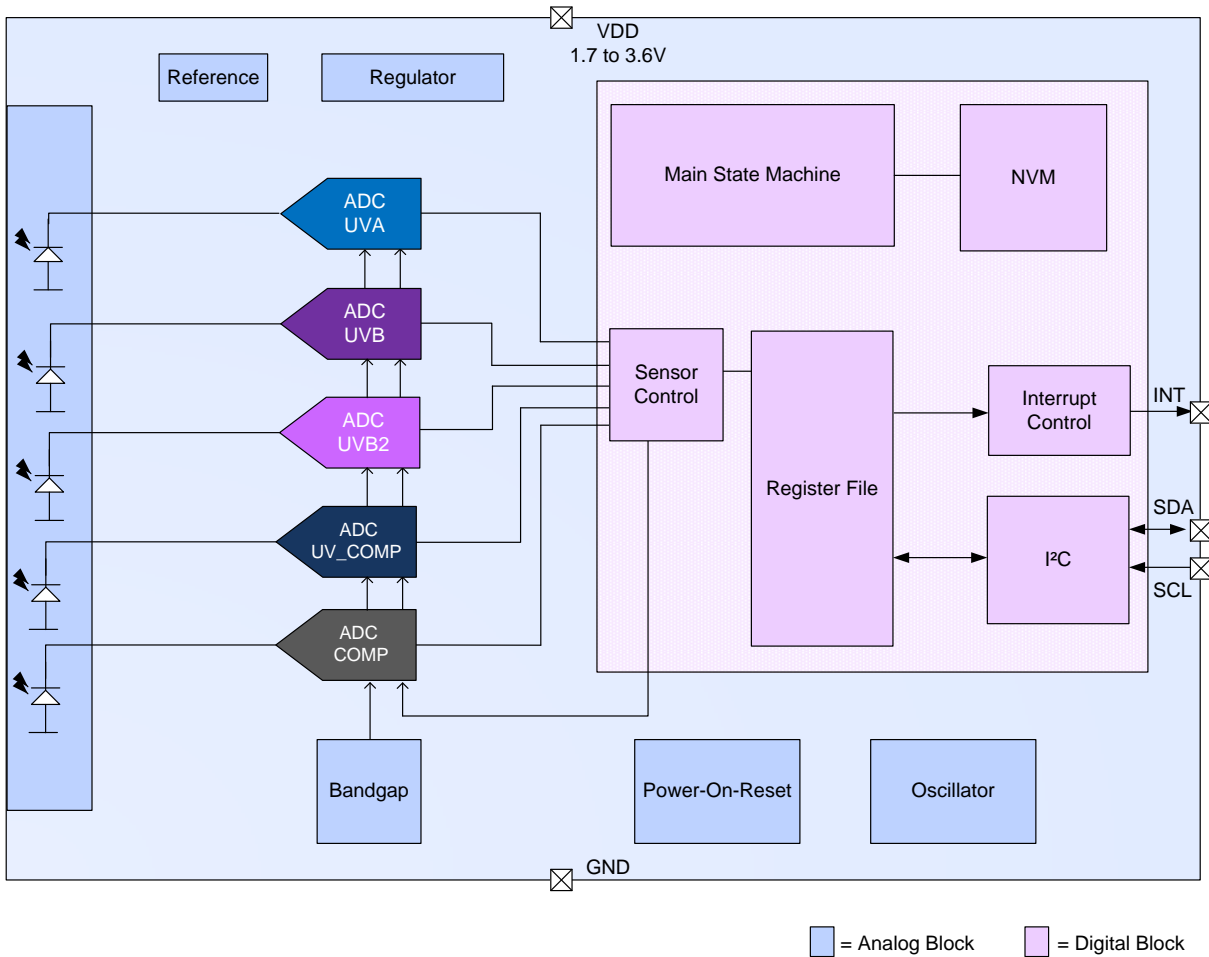

3.2 Application Circuit

Figure 3.2 Typical Application Circuit

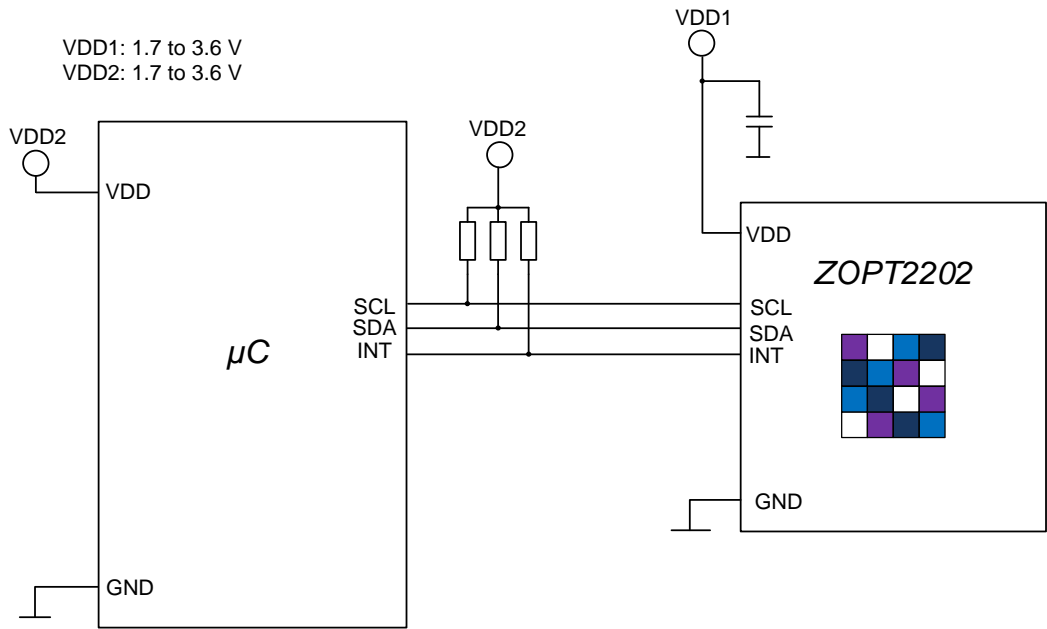

3.3 Pin Description

For pin layout and package dimensions, refer to sections 4.1 and 4.2 for the LGA6 and TSV packages respectively.

Table 3.1 LGA Pin Description

Number	Pin Name	I/O Type	Description
1	SCL	IN	I ² C serial clock line
2	SDA	IN/OUT	I ² C serial data line
3	VDD	SUPPLY	Digital/analog power supply
4	INT	OUT	Interrupt pin
5	GND	GROUND	Digital/analog ground
6	N.C.	-	Not connected

Table 3.2 TSV Pin Description

Number	Pin Name	I/O Type	Description
A1	INT	OUT	Interrupt pin
A2	SDA	IN/OUT	I ² C serial data line
A3	N.C.	-	Not connected
B1	GND	GROUND	Digital/analog ground
B2	VDD	SUPPLY	Digital/analog power supply
B3	SCL	IN	I ² C serial clock line

3.4 Device Operation Modes

Table 3.3 Mode Descriptions

Mode Number	Mode Name	Comment
1	Standby	Default mode after power-up. In this mode, the oscillator, all internal support blocks, and the ADCs are switched off but I ² C communication is fully supported.
2	UVAB_S	<p><u>Active ADC Channels:</u> UVA, UVB2, COMP</p> <p>UVAB_S Mode provides the ZOPT2202's internal temperature and stray light compensation for the UVA and UVB2 sensor output data.</p> <ul style="list-style-type: none"> • UVAB_S Mode is a standard operation mode of the ZOPT2202 that is available for activation after power-up or any ZOPT2202 reset. It does not require additional initialization commands to be sent before activation. • Note: Internal temperature and stray light compensation is based on COMP channel data. • Note: The COMP channel is located aside from the sensor matrix. Hence, stray light compensation is not perfectly matched to the UVA and UVB2 sense elements. • Temperature compensation is optimum. • UVAB_S Mode is activated by setting the <i>LS_EN</i> bit to 1 and set the <i>RawMode_SEL</i> bit to 0 in the <i>MAIN_CTRL</i> register (see section 3.10.1) <ul style="list-style-type: none"> ○ Write 02_{HEX} to register 00_{HEX} • Internal temperature and stray light compensation is performed following the calculation before sensor data is stored in the output register: <ul style="list-style-type: none"> ○ UVA = UVA_{raw} – COMP ○ UVB2 = UVB2_{raw} – COMP
3	UVB_ONLY	<p><u>Active ADC Channels:</u> UVB, UV_COMP</p> <p>UVB_ONLY Mode allows high precision measurements of UVB energy intensity. The sensor response is chosen such that it can be used to calculate the UV index directly.</p> <p>Temperature and stray light compensation for the sensor channel is performed internally via the UV_COMP channel.</p> <ul style="list-style-type: none"> • UVB_ONLY Mode is a standard operation mode of the ZOPT2202 that is available for activation after power-up or any ZOPT2202 reset. It does not require additional initialization commands to be sent before activation. • Note: Internal temperature and stray light compensation is based on the UV_COMP channel data. • Note: The UV_COMP channel is located within sensor matrix. Hence, this mode provides optimum temperature and stray light compensation for UVB channel. • UVB Mode is activated by setting the <i>LS_EN</i> and <i>UVB_ONLY</i> bits to 1 in the <i>MAIN_CTRL</i> register (see section 3.10.1) <ul style="list-style-type: none"> ○ Write 0A_{HEX} to register 00_{HEX} • Internal temperature and stray light compensation is performed following the calculation before sensor data is stored in the output register: <ul style="list-style-type: none"> ○ UVB = UVB_{raw} – UV_COMP

Mode Number	Mode Name	Comment
4	UVAB_Raw	<p><u>Active ADC Channels:</u> UVA, UVB, UVB2, UV_COMP, COMP</p> <p>UVAB_Raw Mode allows optimum temperature and stray light compensation for UVA and UVB sensor output data by external post-processing.</p> <ul style="list-style-type: none"> UVAB_Raw Mode uses a special operation mode of the ZOPT2202. It requires a specific sequence to initialize after power up. The following commands must be sent via I²C <i>single byte</i> access to activate the special operation mode of ZOPT2202: <ul style="list-style-type: none"> Write B5_{HEX} to register 31_{HEX} Write DF_{HEX} to register 30_{HEX} Write 04_{HEX} to register 31_{HEX} UVAB_Raw operation is activated (after the sequence above has been sent) by setting the <i>LS_EN</i> and <i>RawMode_SEL</i> bits to 1 and setting the <i>UVB_Only</i> bit to 0 in the <i>MAIN_CTRL</i> register (see section 3.10.1) <ul style="list-style-type: none"> Write 06_{HEX} to register 00_{HEX} No internal temperature and stray light compensation is carried out. All channel data registers carry the <i>uncompensated raw data</i> as received from ADCs Important: Proper temperature and stray light <i>compensation must be done on the application level</i> applying following formulas: <ul style="list-style-type: none"> $UVA = UVA_raw - UV_COMP$ $UVB = UVB_raw - UV_COMP$ <p>Important: The internal digital trimming factors are not applied to the output data in the UVAB_Raw Mode. If this mode is used, contact IDT for the related application note (see contact information on last page).</p>

Table 3.4 Channel Activation vs. Operation Mode

Mode Number	Mode Name	UVA		UVB		UVB2		UV_COMP		COMP	
		Inactive	Active	Inactive	Active	Inactive	Active	Inactive	Active	Inactive	Active
1	Standby	✓		✓		✓		✓		✓	
2	UVAB_S		✓	✓			✓	✓			✓
3	UVB_ONLY	✓			✓	✓			✓	✓	
4	UVAB_Raw		✓		✓		✓		✓		✓

3.5 Conversion Control State Machine

3.5.1 Start Up after Power-On or Software Reset

The main state machine is set to “Start State” during power-on or software reset. As soon as the reset is released, the internal oscillator is started and the programmed I²C address and the trim values are read from the internal NVM trimming data block. The ZOPT2202 enters Standby Mode as soon as the Idle State is reached as shown in Figure 3.3.

NOTE: If the I²C address has not yet been read, the device will respond with NACK to any I²C command and ignore any request to avoid responding to an incorrect I²C address.

If any of the UV operation modes become activated through an I²C command (i.e., the *LS_EN* bit is set to 1 and the UV mode is selected with the respective bits in the *MAIN_CTRL* register), the internal support blocks are immediately powered on. Once the voltages and currents are settled (typical after 500µs), the state machine checks for trigger events from a measurement scheduler to start conversions according to the selected measurement repeat rates (see section 3.10.2).

When the user resets the *LS_EN* bit to 0, a running conversion will be completed and the relevant ADCs and support blocks will move to Standby Mode thereafter.

Figure 3.3 Main State Machine

Note: See Table 3.4 for a list of the light sensor channels that are active for the configured LS mode.

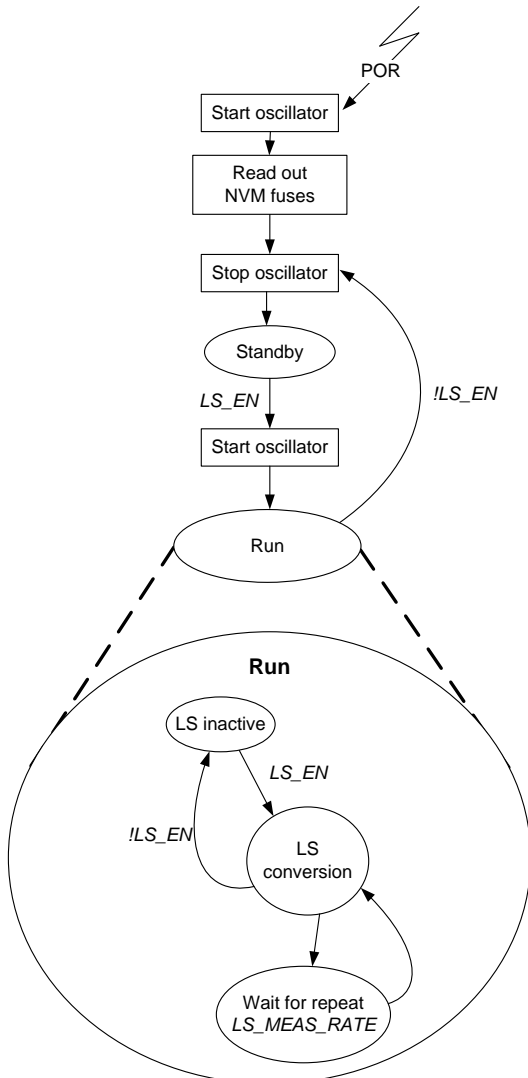

3.6 UV Sensor Sensitivity Configuration

3.6.1 Analog Gain Modes, Resolution, and Measurement Time

There are five analog gain modes to adjust sensitivity of the ZOPT2202 device to the needs of the application. The microcontroller can calculate the received UV energy by multiplying the sensor output data with the appropriate output-scaling coefficients.

If UVAB_Raw Mode is used, temperature and stray light compensation shall be carried out in the microcontroller before output scaling coefficients are applied (see section 3.4. for the UVAB_Raw Mode description).

Selected analog gain settings as well as resolution and measurement time settings are valid for all ADC converter channels at the same time. The gain, resolution, and measurement time cannot be simultaneously set to different settings for different channels. If different gain or resolution settings are required for different channels, conversions have to be carried out with modified settings one after another.

Table 3.5 UVAS Sensitivities

Effective Output Resolution [Bits]	Measurement Time [ms]	Gain Mode 1	Gain Mode 3	Gain Mode 6	Gain Mode 9	Gain Mode 18
		Sensitivity $\left[\frac{\text{counts}}{\mu\text{W}/\text{cm}^2} \right]$	Sensitivity $\left[\frac{\text{counts}}{\mu\text{W}/\text{cm}^2} \right]$	Sensitivity $\left[\frac{\text{counts}}{\mu\text{W}/\text{cm}^2} \right]$	Sensitivity $\left[\frac{\text{counts}}{\mu\text{W}/\text{cm}^2} \right]$	Sensitivity $\left[\frac{\text{counts}}{\mu\text{W}/\text{cm}^2} \right]$
13	3.125	0.074	0.221	0.443	0.664	1.328
16	25	0.590	1.771	3.542	5.313	10.625
17	50	1.181	3.542	7.083	10.625	21.250
18 (default)	100	2.361	7.083	14.167	21.250	42.500
19	200	4.722	14.167	28.333	42.500	85.000
20	400	9.444	28.333	56.667	85.000	170.000

Table 3.6 UVBS Sensitivities

Effective Output Resolution [Bits]	Measurement Time [ms]	Gain Mode 1	Gain Mode 3	Gain Mode 6	Gain Mode 9	Gain Mode 18
		Sensitivity $\left[\frac{\text{counts}}{\mu\text{W}/\text{cm}^2} \right]$	Sensitivity $\left[\frac{\text{counts}}{\mu\text{W}/\text{cm}^2} \right]$	Sensitivity $\left[\frac{\text{counts}}{\mu\text{W}/\text{cm}^2} \right]$	Sensitivity $\left[\frac{\text{counts}}{\mu\text{W}/\text{cm}^2} \right]$	Sensitivity $\left[\frac{\text{counts}}{\mu\text{W}/\text{cm}^2} \right]$
13	3.125	0.022	0.065	0.130	0.195	0.391
16	25	0.174	0.521	1.042	1.563	3.125
17	50	0.347	1.042	2.083	3.125	6.250
18 (default)	100	0.694	2.083	4.167	6.250	12.500
19	200	1.389	4.167	8.333	12.500	25.000
20	400	2.778	8.333	16.667	25.000	50.000

3.7 Interrupt Features

The ZOPT2202 can generate an interrupt signal on a user selectable sensor channel. Interrupts will be triggered if upper or lower threshold values are crossed or if output count variation of consecutive conversions has exceeded a defined limit.

An interrupt can be indicated at the INT pin as an active low signal or via a status register flag. Interrupt conditions are always evaluated after completion of a new conversion on the selected sensor channel.

The *Is_int* signal (output of LSIntGen in Figure 3.4) is also stored in the *MAIN_STATUS* register as the *LS interrupt status* (see section 3.10.5) flag. The flag is cleared by reading the *MAIN_STATUS* register. A cleared *LS interrupt status* flag will also clear the interrupt signal on the INT pin.

Figure 3.4 Interrupt Unit

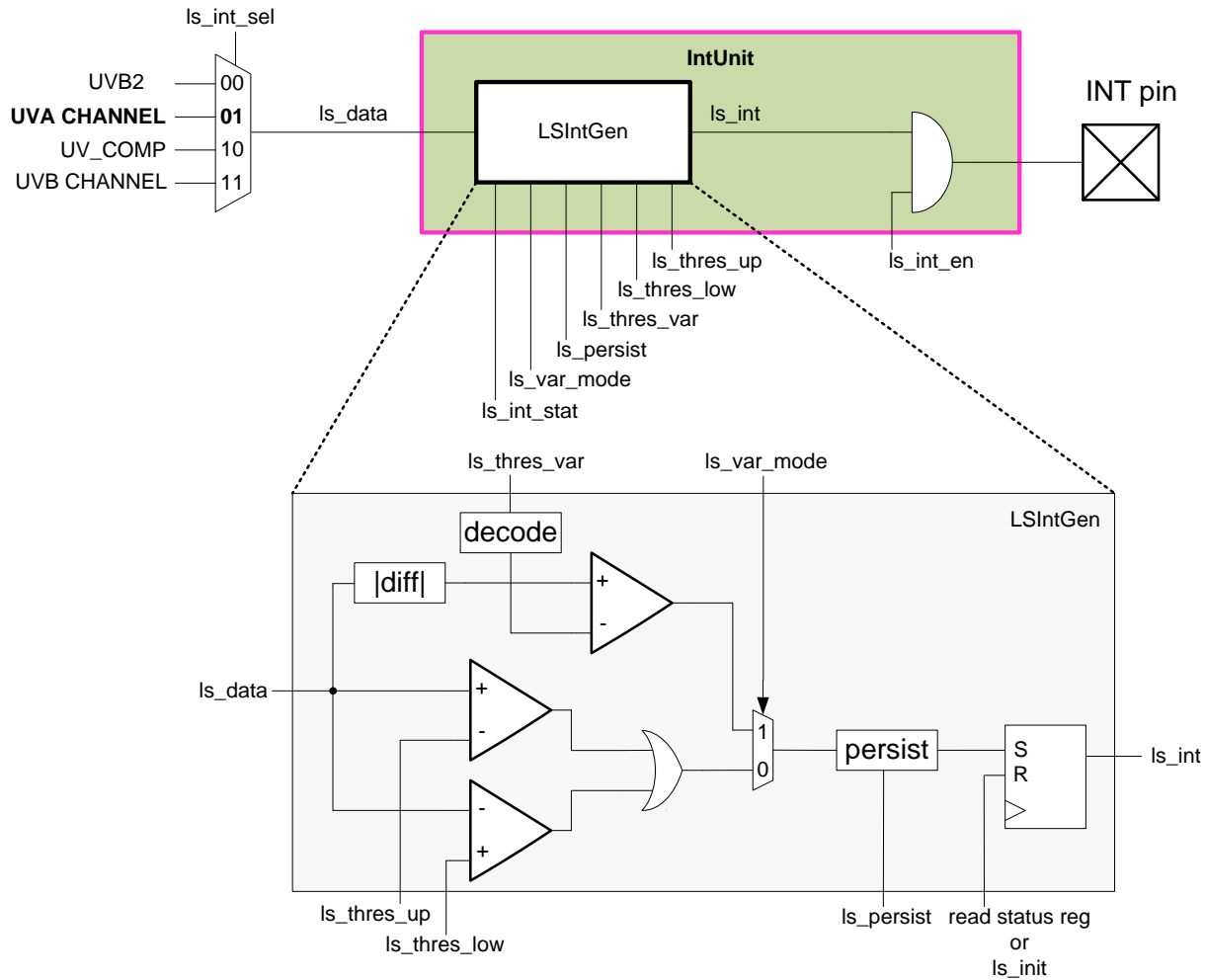

The interrupt is configured by the bits in the *INT_CFG* register (see section 3.10.11). The interrupt is enabled by setting the bit *LS_INT_EN* = 1. It can function as either threshold-triggered (*LS_VAR_MODE* = 0) or variance-triggered (*LS_VAR_MODE* = 1).

The interrupt source generator is configurable to be one of the following input channels: UVA, UVB, UVB2, or UV_COMP. The interrupt source is selected by the *LS_INT_SEL* bits.

The threshold interrupt is enabled with $LS_INT_EN = 1$ and $LS_VAR_MODE = 0$. The interrupt is set when the respective \ast_DATA register value of the selected interrupt source channel is above the upper or below the lower threshold configured in the LS_THRES_UP and LS_THRES_LOW registers (see sections 3.10.13 and 3.10.14 respectively) for a specified number of consecutive measurements as configured in the INT_PST register ($1+LS_PERSIST$; see section 3.10.12).

The variance interrupt is enabled with $LS_INT_EN = 1$ and $LS_VAR_MODE = 1$. It is set when the absolute value difference between the preceding and the current output data of the selected interrupt source channel is above the decoded variance threshold (see section 3.10.15) for a specified number of consecutive measurements ($1+LS_PERSIST$).

3.8 I²C Interface

The ZOPT2202 is equipped with an I²C interface for control and data communication. The chip always operates as a slave. The device offers two different 7-bit slave addresses that are selectable via NVM programming. A read/write bit must be appended to the slave address by the master device to properly communicate with the device.

The interface is compatible with Standard Mode (100kHz) and Fast Mode (400kHz) I²C communication.

Table 3.7 Supported I²C Clock Frequencies

Mode	Frequency	Transient Noise Filter
Standard	100kHz	50ns
Fast	400kHz	50ns

The I²C circuitry is always active (Standby or Active Mode of the ZOPT2202). If the I²C address has not yet been read from the memory block, the device will respond with “NACK” to any request and ignore the possible commands. An attempt to read or write to non-existing addresses will be answered with “NACK.”

3.8.1 I²C Address Decoding

The I²C address decoding is done during start up after power-on-reset or software reset. Two different I²C addresses can be selected through NVM programming (see Table 3.8).

Table 3.8 I²C Address

Address NVM Level	I ² C Address		
	7 Bits	Write	Read
0 – default	1010 011 _{XBIN}	A6 _{HEX}	A7 _{HEX}
1 – programmed	1010 010 _{XBIN}	A4 _{HEX}	A5 _{HEX}

3.8.2 I²C Register Read

The ZOPT2202 registers can be read individually or in block read mode. When two or more bytes are read in block read mode, reserved register addresses are skipped and the next valid address is referenced. If the last valid address has been reached, but the master continues with the block read, the address counter in the ZOPT2202 will not roll over and the ZOPT2202 returns 00_{HEX} for every subsequent byte read.

The block read operation is the only way to ensure correct data read out of multi-byte registers and to avoid splitting of results with HIGH and LOW bytes originating from different conversions. During block read access on the sensor \ast_DATA registers, the result update is blocked.

If a read access is started on an address of a non-readable register, the ZOPT2202 will return NACK until the I²C operation is ended.

Read operations must follow the timing diagram in Figure 3.5.

Figure 3.5 I²C Register Read

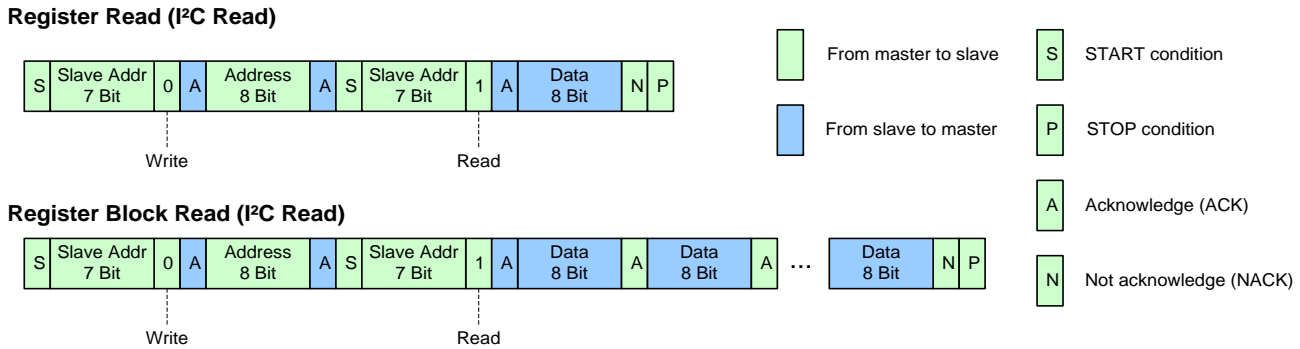

3.8.3 Register Write

The ZOPT2202 registers can be written to individually or in block write mode. When two or more bytes are written in block write mode, reserved registers and read-only registers are skipped. The transmitted data is automatically applied to the next writable register. If a register includes read (R) and read/write (RW) bits, the register is not skipped. Data written to read-only bits are ignored.

If the last valid address of the ZOPT2202's address range is reached but the master attempts to continue the block write operation, the address counter of the ZOPT2202 will not roll over. The ZOPT2202 will return NACK for every following byte sent by the master until the I²C operation is ended.

If a write access is started on an address of a non-writable register, the ZOPT2202 will return NACK until the I²C operation is ended.

Write operations must follow the timing diagram in Figure 3.6.

Figure 3.6 I²C Register Write

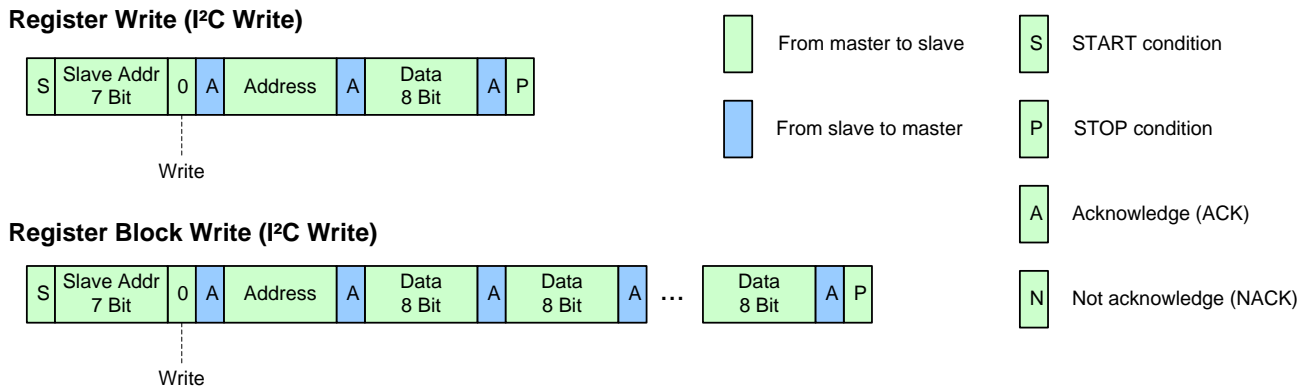

3.8.4 I²C Interface—Bus Timing

Figure 3.7 Bus Timing

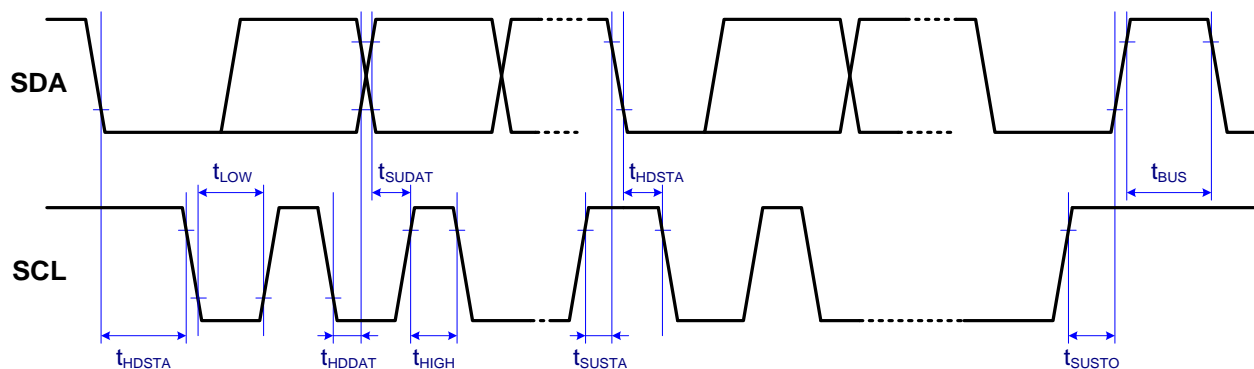

Table 3.9 Bus Timing Characteristic

PARAMETER	SYMBOL	Standard Mode	Fast Mode	UNITS
Maximum SCL clock frequency	f_{SCL}	100	400	kHz
Minimum START condition hold time relative to SCL edge	t_{HDSTA}	4		μ S
Minimum SCL clock low width	t_{LOW}	4.7		μ S
Minimum SCL clock high width	t_{HIGH}	4		μ S
Minimum START condition setup time relative to SCL edge	t_{SUSTA}	4.7		μ S
Minimum data hold time on SDA relative to SCL edge	t_{HDDAT}	0		μ S
Minimum data setup time on SDA relative to SCL edge	t_{SUDAT}	0.1	0.1	μ S
Minimum STOP condition setup time on SCL	t_{SUSTO}	4		μ S
Minimum bus free time between stop condition and start condition	t_{BUS}	4.7		μ S

3.9 Summary of Internal Registers

Table 3.10 Register Overview

Address	Type	Name	Default Value	Description
00 _{HEX}	RW	MAIN_CTRL	00 _{HEX}	Operation mode control, software (SW) reset
04 _{HEX}	RW	LS_MEAS_RATE	22 _{HEX}	Measurement rate and resolution setting
05 _{HEX}	RW	LS_GAIN	01 _{HEX}	Analog gain range setting
06 _{HEX}	R	PART_ID	B2 _{HEX}	Part number ID and revision ID
07 _{HEX}	R	MAIN_STATUS	20 _{HEX}	Power-on status, interrupt status, data status
0A _{HEX}	R	UVB2_DATA_0	00 _{HEX}	UVB2 - ADC measurement data, LSB
0B _{HEX}	R	UVB2_DATA_1	00 _{HEX}	UVB2 - ADC measurement data
0C _{HEX}	R	UVB2_DATA_2	00 _{HEX}	UVB2 - ADC measurement data, MSB
0D _{HEX}	R	UVA_DATA_0	00 _{HEX}	UVA - ADC measurement data, LSB
0E _{HEX}	R	UVA_DATA_1	00 _{HEX}	UVA - ADC measurement data
0F _{HEX}	R	UVA_DATA_2	00 _{HEX}	UVA - ADC measurement data, MSB
10 _{HEX}	R	UVB_DATA_0	00 _{HEX}	UVB - ADC measurement data, LSB
11 _{HEX}	R	UVB_DATA_1	00 _{HEX}	UVB - ADC measurement data
12 _{HEX}	R	UVB_DATA_2	00 _{HEX}	UVB - ADC measurement data, MSB
13 _{HEX}	R	UV_COMP_DATA_0	00 _{HEX}	UV_COMP - ADC measurement data, LSB
14 _{HEX}	R	UV_COMP_DATA_1	00 _{HEX}	UV_COMP - ADC measurement data
15 _{HEX}	R	UV_COMP_DATA_2	00 _{HEX}	UV_COMP - ADC measurement data, MSB
16 _{HEX}	R	COMP_DATA_0	00 _{HEX}	COMP - ADC measurement data, LSB
17 _{HEX}	R	COMP_DATA_1	00 _{HEX}	COMP - ADC measurement data
18 _{HEX}	R	COMP_DATA_2	00 _{HEX}	COMP - ADC measurement data, MSB
19 _{HEX}	RW	INT_CFG	10 _{HEX}	Interrupt configuration
1A _{HEX}	RW	INT_PST	00 _{HEX}	Interrupt persist setting
21 _{HEX}	RW	LS_THRES_UP_0	FF _{HEX}	Interrupt upper threshold, LSB
22 _{HEX}	RW	LS_THRES_UP_1	FF _{HEX}	Interrupt upper threshold, intervening bits
23 _{HEX}	RW	LS_THRES_UP_2	0F _{HEX}	Interrupt upper threshold, MSB
24 _{HEX}	RW	LS_THRES_LOW_0	00 _{HEX}	Interrupt lower threshold, LSB
25 _{HEX}	RW	LS_THRES_LOW_1	00 _{HEX}	Interrupt lower threshold, intervening bits
26 _{HEX}	RW	LS_THRES_LOW_2	00 _{HEX}	Interrupt lower threshold, MSB

3.10.2 LS_MEAS_RATE

Address 04_{HEX}
 Default value 22_{HEX}
 Register access RW

Bit	7	6	5	4	3	2	1	0
04 _{HEX}	0	LS Resolution / Bit Width			0	LS Measurement Rate		

Bit[6:4] *Light Sensor Resolution/ Bit Width.* The resolution selected via this register will have an effect on the measurement time and the accuracy of the measurement.

- 000_{BIN} 20-Bit – 400ms
- 001_{BIN} 19-Bit – 200ms
- 010_{BIN} 18-Bit – 100ms **(default)**
- 011_{BIN} 17-Bit – 50ms
- 100_{BIN} 16-Bit – 25ms
- 101_{BIN} 13-Bit – 3.125ms
- 110_{BIN} Reserved
- 111_{BIN} Reserved

Bit[2:0] *LS Measurement Rate.* This bit field controls the timing of the periodic measurements of the light sensor in Active Mode.

- 000_{BIN} 25ms
- 001_{BIN} 50ms
- 010_{BIN} 100ms **(default)**
- 011_{BIN} 200ms
- 100_{BIN} 500ms
- 101_{BIN} 1000ms
- 110_{BIN} 2000ms
- 111_{BIN} 2000ms



Note: When the measurement repeat rate is programmed to be faster than possible for the specified ADC measurement time, the repeat rate will be lower than programmed (maximum speed).

Writing to this register stops the ongoing measurements and starts new measurements (depending on the respective enable bits).

3.10.3 LS_GAIN

Address 05_{HEX}
 Default value 01_{HEX}
 Register access RW

Bit	7	6	5	4	3	2	1	0
05 _{HEX}	0	0	0	0	0	LS Gain Range		

Note: The following UVA / UVB detection ranges apply to the 20-bit resolution setting (measurement time = 400ms); see Table 3.5 and Table 3.6 for further details.

LS Detection Ranges:

Bit[2:0]	UVA Sensor (temperature and stray light compensated):			
	000 _{BIN}	Gain: 1	0.106 to 111026	μW/cm ²
	001 _{BIN}	Gain: 3 (default)	0.035 to 37009	μW/cm ²
	010 _{BIN}	Gain: 6	0.018 to 18504	μW/cm ²
	011 _{BIN}	Gain: 9	0.012 to 12336	μW/cm ²
	100 _{BIN}	Gain: 18	0.006 to 6168	μW/cm ²

Bit[2:0]	UVB Sensor (temperature and stray light compensated):			
	000 _{BIN}	Gain: 1	0.36 to 377487	μW/cm ²
	001 _{BIN}	Gain: 3 (default)	0.086 to 125829	μW/cm ²
	010 _{BIN}	Gain: 6	0.043 to 62915	μW/cm ²
	011 _{BIN}	Gain: 9	0.029 to 41943	μW/cm ²
	100 _{BIN}	Gain: 18	0.014 to 20972	μW/cm ²

Writing to this register stops the ongoing measurements and starts new measurements (depending on the respective enable bits).

3.10.4 PART_ID

Address 06_{HEX}
 Default value B2_{HEX}
 Register access R

Bit	7	6	5	4	3	2	1	0
06 _{HEX}	Part Number ID				Revision ID			

Bit[7:4] Part number ID

Bit[3:0] Revision ID of the component. The value increases by one each time a new silicon revision is manufactured

3.10.5 MAIN_STATUS

Address 07_{HEX}
 Default value 20_{HEX}
 Register access R

Bit	7	6	5	4	3	2	1	0
07 _{HEX}	0	0	Power-On status	LS interrupt status	LS data status	0	0	0

Bit[5] *Power-On status*. If set to 1, the part went through a power-up event, either because the part was turned on or because there was a power-supply voltage disturbance

A value of 1 is the default at first register read after power-on reset.

Note: All interrupt threshold settings in the registers have been reset to power-on default states and should be examined if the *Power-On status* flag is set.

The special operation mode needed for UVAB_Raw Mode is turned off if a power-up event occurs and the mode must be initialized before UVAB_Raw Mode activation.

The flag is cleared after the register is read.

Bit[4] *LS interrupt status* (updated even when the interrupt pin is disabled)
 0 interrupt condition has not occurred (**default**)
 1 interrupt condition has occurred (cleared after read)

Bit[3] *LS data status*
 0 old data, already read (**default**)
 1 new data, not yet read (cleared after read)

Bit[2:0] Reserved

3.10.6 UVB2_DATA

Address 0A_{HEX} and 0B_{HEX} and 0C_{HEX}
 Default value 00_{HEX} and 00_{HEX} and 00_{HEX}
 Register access R

Bit	7	6	5	4	3	2	1	0
0A _{HEX}	UVB2_DATA_0[7:0]							
0B _{HEX}	UVB2_DATA_1[15:8]							
0C _{HEX}	0	0	0	0	UVB2_DATA_2[19:16]			

UVB2 channel digital output data (unsigned integer, 13 to 20 bit, LSB aligned).

Applied temperature and stray light compensation depends on operation mode. See section 3.4 for details.

When an I²C read operation is active and points to an address in the range 07_{HEX} to 18_{HEX}, all registers in this range are locked until the I²C read operation is completed or this address range is left.

This guarantees that the data in the registers belongs to the same measurement cycle. New measurement data is stored into temporary registers and the actual *_DATA registers are updated as soon as there is no on-going I²C read operation in the address range 07_{HEX} to 18_{HEX}.

Register 0A_{HEX} Bit[7:0] UVB2 diode data least significant data byte
 Register 0B_{HEX} Bit[7:0] UVB2 diode data intervening data byte
 Register 0C_{HEX} Bit[3:0] UVB2 diode data most significant data byte

3.10.7 UVA_DATA

Address 0D_{HEX} and 0E_{HEX} and 0F_{HEX}
 Default value 00_{HEX} and 00_{HEX} and 00_{HEX}
 Register access R

Bit	7	6	5	4	3	2	1	0
0D _{HEX}	UVA_DATA_0[7:0]							
0E _{HEX}	UVA_DATA_1[15:8]							
0F _{HEX}	0	0	0	0	UVA_DATA_2[19:16]			

UVA channel digital output data (unsigned integer, 13 to 20 bit, LSB aligned).

Applied temperature and stray light compensation depends on operation mode. See section 3.4 for details.

When an I²C read operation is active and points to an address in the range 07_{HEX} to 18_{HEX}, all registers in this range are locked until the I²C read operation is completed or this address range is left.

This guarantees that the data in the registers belongs to the same measurement cycle. New measurement data is stored into temporary registers and the actual *_DATA registers are updated as soon as there is no on-going I²C read operation in the address range 07_{HEX} to 18_{HEX}.

Register 0D _{HEX}	Bit[7:0]	UVA diode data least significant data byte
Register 0E _{HEX}	Bit[7:0]	UVA diode data intervening data byte
Register 0F _{HEX}	Bit[3:0]	UVA diode data most significant data byte

3.10.8 UVB_DATA

Address 10_{HEX} and 11_{HEX} and 12_{HEX}
 Default value 00_{HEX} and 00_{HEX} and 00_{HEX}
 Register access R

Bit	7	6	5	4	3	2	1	0
10 _{HEX}	UVB_DATA_0[7:0]							
11 _{HEX}	UVB_DATA_1[15:8]							
12 _{HEX}	0	0	0	0	UVB_DATA_2[19:16]			

UVB channel digital output data (unsigned integer, 13 to 20 bit, LSB aligned).

Applied temperature and stray light compensation depends on operation mode. See section 3.4 for details.

When an I²C read operation is active and points to an address in the range 07_{HEX} to 18_{HEX}, all registers in this range are locked until the I²C read operation is completed or this address range is left.

This guarantees that the data in the registers belongs to the same measurement cycle. New measurement data is stored into temporary registers and the actual *_DATA registers are updated as soon as there is no on-going I²C read operation in the address range 07_{HEX} to 18_{HEX}.

Register 10 _{HEX}	Bit[7:0]	UVB diode data least significant data byte
Register 11 _{HEX}	Bit[7:0]	UVB diode data intervening data byte
Register 12 _{HEX}	Bit[3:0]	UVB diode data most significant data byte

3.10.9 UV_COMP_DATA

Address 13_{HEX} and 14_{HEX} and 15_{HEX}
 Default value 00_{HEX} and 00_{HEX} and 00_{HEX}
 Register access R

Bit	7	6	5	4	3	2	1	0
13 _{HEX}	UV_COMP_DATA_0[7:0]							
14 _{HEX}	UV_COMP_DATA_1[15:8]							
15 _{HEX}	0	0	0	0	UV_COMP_DATA_2[19:16]			

Digital output data from the temperature and stray light compensation channel for UVB data (UV_COMP) (unsigned integer, 13 to 20 bit, LSB aligned).

Applied compensation depends on operation mode. See section 3.4 for details.

When an I²C read operation is active and points to an address in the range 07_{HEX} to 18_{HEX}, all registers in this range are locked until the I²C read operation is completed or this address range is left.

This guarantees that the data in the registers belongs to the same measurement cycle. New measurement data is stored into temporary registers and the actual *_DATA registers are updated as soon as there is no on-going I²C read operation in the address range 07_{HEX} to 18_{HEX}.

Register 13 _{HEX}	Bit[7:0]	UV_COMP diode data least significant data byte
Register 14 _{HEX}	Bit[7:0]	UV_COMP diode data intervening data byte
Register 15 _{HEX}	Bit[3:0]	UV_COMP diode data most significant data byte

3.10.10 COMP_DATA

Address 16_{HEX} and 17_{HEX} and 18_{HEX}
 Default value 00_{HEX} and 00_{HEX} and 00_{HEX}
 Register access R

Bit	7	6	5	4	3	2	1	0
16 _{HEX}	COMP_DATA_0[7:0]							
17 _{HEX}	COMP_DATA_1[15:8]							
18 _{HEX}	0	0	0	0	COMP_DATA_2[19:16]			

Digital output data from the temperature and stray light compensation channel for UVA and UVB2 data (COMP) (unsigned integer, 13 to 20 bit, LSB aligned).

Applied compensation depends on operation mode. See section 3.4 for details.

When an I²C read operation is active and points to an address in the range 07_{HEX} to 18_{HEX}, all registers in this range are locked until the I²C read operation is completed or this address range is left.

This guarantees that the data in the registers belongs to the same measurement cycle. New measurement data is stored into temporary registers and the actual *_DATA registers are updated as soon as there is no on-going I²C read operation in the address range 07_{HEX} to 18_{HEX}.

Register 16_{HEX} Bit[7:0] COMP diode data least significant data byte
 Register 17_{HEX} Bit[7:0] COMP diode data intervening data byte
 Register 18_{HEX} Bit[3:0] COMP diode data most significant data byte

3.10.11 INT_CFG

Address 19_{HEX}
 Default value 10_{HEX}
 Register access RW

Bit	7	6	5	4	3	2	1	0
19 _{HEX}	0	0	LS_INT_SEL		LS_VAR_MODE	LS_INT_EN	0	0

- Bit[5:4] *LS_INT_SEL* Light sensor interrupt source select
 00 UVB2 channel
 01 UVA channel (**default**)
 10 UV_COMP channel
 11 UVB channel
- Bit[3] *LS_VAR_MODE* Light sensor variation interrupt mode
 0 Threshold Interrupt Mode (**default**)
 1 Variation Interrupt Mode
- Bit[2] *LS_INT_EN* Light sensor interrupt enable
 0 Interrupt disabled (**default**)
 1 Interrupt enabled

3.10.12 INT_PST

Address 1A_{HEX}
 Default value 00_{HEX}
 Register access RW

Bit	7	6	5	4	3	2	1	0
1A _{HEX}	LS_PERSIST				0	0	0	0

- Bit[7:4] This register sets the number of similar consecutive light sensor (LS) interrupt events that must occur before the interrupt is asserted.
 0000_{BIN} Every LS value out of threshold range (**default**) asserts an interrupt.
 0001_{BIN} 2 consecutive LS values out of threshold range assert an interrupt.
 ...
 1111_{BIN} 16 consecutive LS values out of threshold range assert an interrupt.
- Bit[3:0] Reserved.

3.10.13 LS_THRES_UP

Address 21_{HEX} and 22_{HEX} and 23_{HEX}
 Default value FF_{HEX} and FF_{HEX} and 0F_{HEX}
 Register access RW

Bit	7	6	5	4	3	2	1	0
21 _{HEX}	LS_THRES_UP_0							
22 _{HEX}	LS_THRES_UP_1							
23 _{HEX}	0	0	0	0	LS_THRES_UP_2			

LS_THRES_UP_x sets the upper threshold value for the LS interrupt.

The interrupt controller compares the value in LS_THRES_UP_x against measured data in the *_DATA_x registers of the selected LS interrupt channel. It generates an interrupt event if *_DATA_x exceeds the threshold level.

The data format for LS_THRES_UP_x must match that of the *_DATA_x registers.

Register 21_{HEX} Bit[7:0] LS upper interrupt threshold value, LSB
 Register 22_{HEX} Bit[7:0] LS upper interrupt threshold value, intervening byte
 Register 23_{HEX} Bit[3:0] LS upper interrupt threshold value, MSB

3.10.14 LS_THRES_LOW

Address 24_{HEX} and 25_{HEX} and 26_{HEX}
 Default value 00_{HEX} and 00_{HEX} and 00_{HEX}
 Register access RW

Bit	7	6	5	4	3	2	1	0
24 _{HEX}	LS_THRES_LOW_0							
25 _{HEX}	LS_THRES_LOW_1							
26 _{HEX}	0	0	0	0	LS_THRES_LOW_2			

LS_THRES_LOW_x sets the lower threshold value for the LS interrupt. The interrupt controller compares the value in LS_THRES_LOW_x against measured data in the *_DATA_x registers of the selected LS interrupt channel. It generates an interrupt event if the *_DATA_x is below the threshold level.

The data format for LS_THRES_LOW_x must match that of the *_DATA_x registers.

Register 24_{HEX} Bit[7:0] LS lower interrupt threshold value, LSB
 Register 25_{HEX} Bit[7:0] LS lower interrupt threshold value, intervening byte
 Register 26_{HEX} Bit[3:0] LS lower interrupt threshold value, MSB

3.10.15 LS_THRES_VAR

Address 27_{HEX}
 Default value 00_{HEX}
 Register access RW

Bit	7	6	5	4	3	2	1	0
27 _{HEX}	0	0	0	0	0	LS_THRES_VAR		

Bit[2:0] LS variance threshold

Code Interrupt generated when

000_{BIN} new DATA_x varies by **8 counts** compared to previous result (**default**)

001_{BIN} new DATA_x varies by **16 counts** compared to previous result

010_{BIN} new DATA_x varies by **32 counts** compared to previous result

011_{BIN} new DATA_x varies by **64 counts** compared to previous result

100_{BIN} new DATA_x varies by **128 counts** compared to previous result

101_{BIN} new DATA_x varies by **256 counts** compared to previous result

110_{BIN} new DATA_x varies by **512 counts** compared to previous result

111_{BIN} new DATA_x varies by **1024 counts** compared to previous result

3.10.16 DEVICE_CONFIG

Address 2F_{HEX}
 Default value 00_{HEX}
 Register access RW

Bit	7	6	5	4	3	2	1	0
2F _{HEX}	0	0	0	0	Reserved	Reserved	I ² C Address	Reserved

Bit[1] I²C Address

0 (**default**) 7-bit format (no R/W bit consideration): 53_{HEX}
 8-bit format (with R/W bit consideration): A6_{HEX} / A7_{HEX}

1 7-bit format (no R/W bit consideration): 52_{HEX}
 8-bit format (with R/W bit consideration): A4_{HEX} / A5_{HEX}

4. Packages

4.1 LGA6 Package (2.0 × 2.2 × 0.7 mm)

4.1.1 Mechanical Dimensions

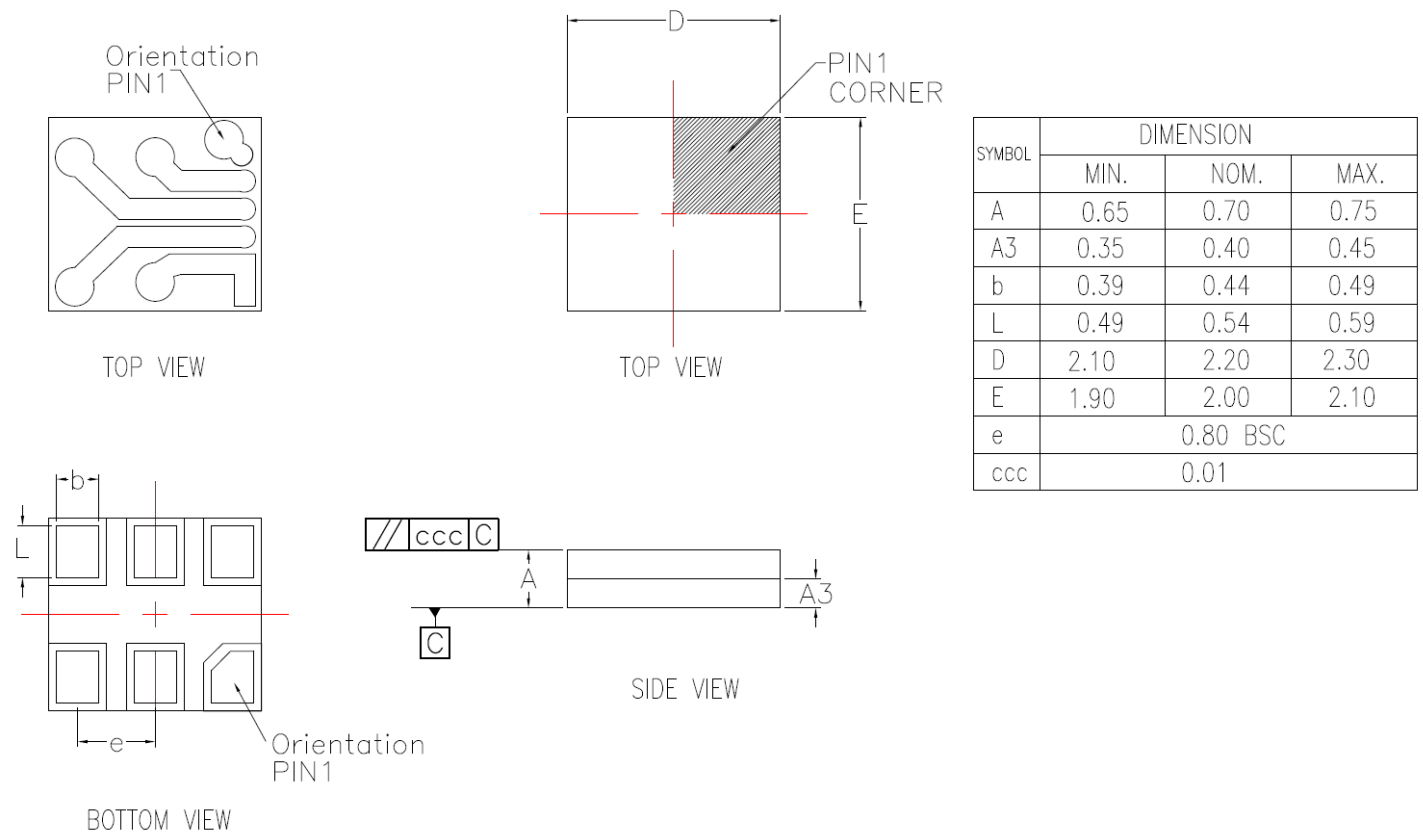

4.1.2 Pin Assignment (Top View)

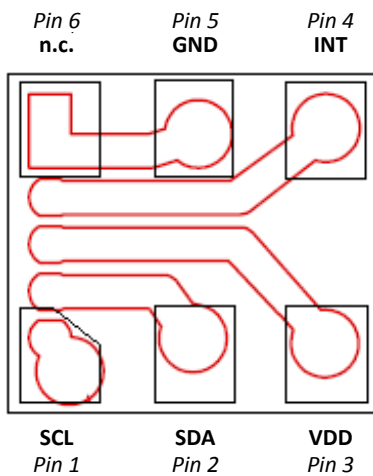

4.1.3 Reflow Profile

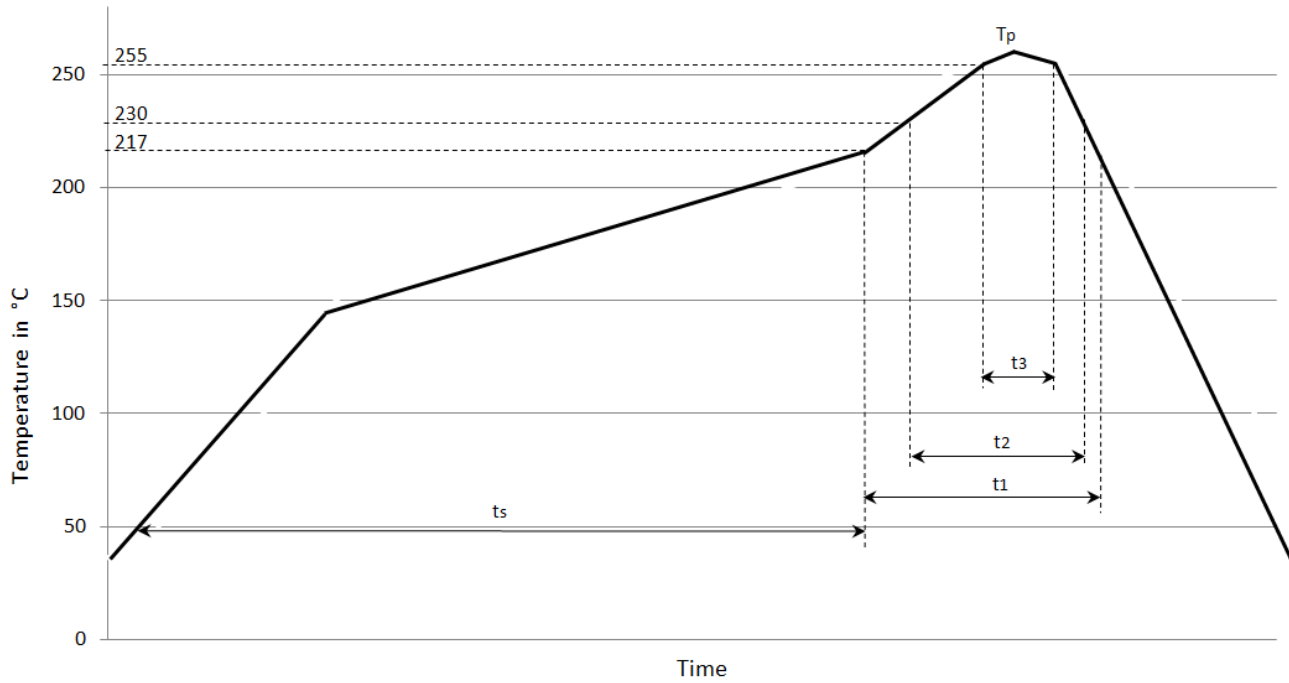
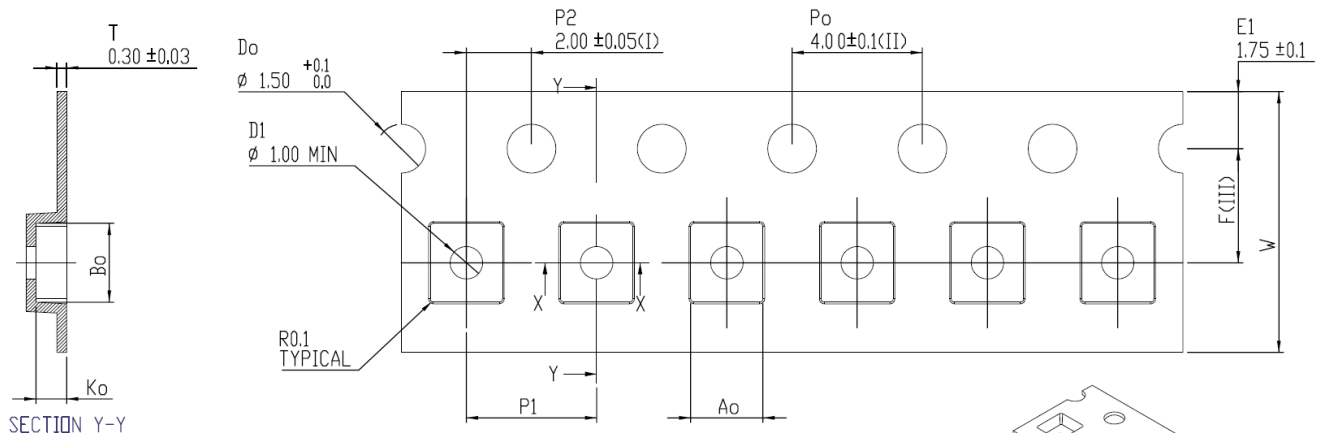

Table 4.1 Reflow Profile Specifications

Parameter	Legend	Component
Time above 217°C	t_1	≤ 60 sec
Time above 230°C	t_2	≤ 50 sec
Time above 255°C	t_3	≤ 15 sec
Peak Temp	T_p	$\leq 260^\circ\text{C}$
Soak Time (50°C – 217°C)	t_s	≤ 180 sec
Temperature Gradient Preheating		< 3 °C/sec
Temperature Gradient Cooling		< 5 °C/sec

4.1.4 LGA Tape Packaging Information



Ao	2,22 +/- 0,1
Bo	2,42 +/- 0,1
Ko	0,95 +/- 0,1
F	3,50 +/- 0,05
P1	4,00 +/- 0,1
W	8,00 +0,3/-0,1

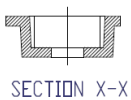

- NOTES : (UNLESS OTHERWISE SPECIFIED)
- SUPPLIER : C-PAK
 - SUPPLIER PART NUMBER : ODFN-2x2.2x0.7 (EM1089-16)
 - Po 10 PITCHES CUMULATIVE TOLERANCE ON TAPE : ±0.20 mm
 - REFER TO MSA-3018 FOR THE ALLOWABLE CAMBER REQUIREMENT.
 - MATERIAL : BLACK CONDUCTIVE POLYSTYRENE.
 - Ao AND Bo MEASURED FROM THE BOTTOM OF THE POCKET.
 - Ko MEASURED FROM A PLANE ON THE INSIDE BOTTOM OF THE POCKET TO THE TOP SURFACE OF THE CARRIER.
 - POCKET POSITION RELATIVE TO SPROCKET HOLE MEASURED AS TRUE POSITION OF POCKET, NOT POCKET HOLE.
 - POCKET CENTER AND POCKET HOLE CENTER MUST BE SAME POSITION.
 - REFER TO MAA-3092 & MSA-3018 FOR THE IDT STANDARD REQUIREMENT FOR CARRIER TAPE.
 - ALL THE DIMENSIONS ARE IN MILLIMETERS (MM).
 - LENGTH PER ROLL = 500 METERS.
 - ALLOWABLE CAMBER TO BE 2/250 MM MAXIMUM.

4.2 TSV Package (1.1 × 1.2 × 0.26 mm)

Note: In the following mechanical diagram, the symbol N refers to the number of pins, N1 refers to the number of pin columns, and N2 refers to the number of rows.

4.2.1 Mechanical Dimensions

Mechanical Diagram

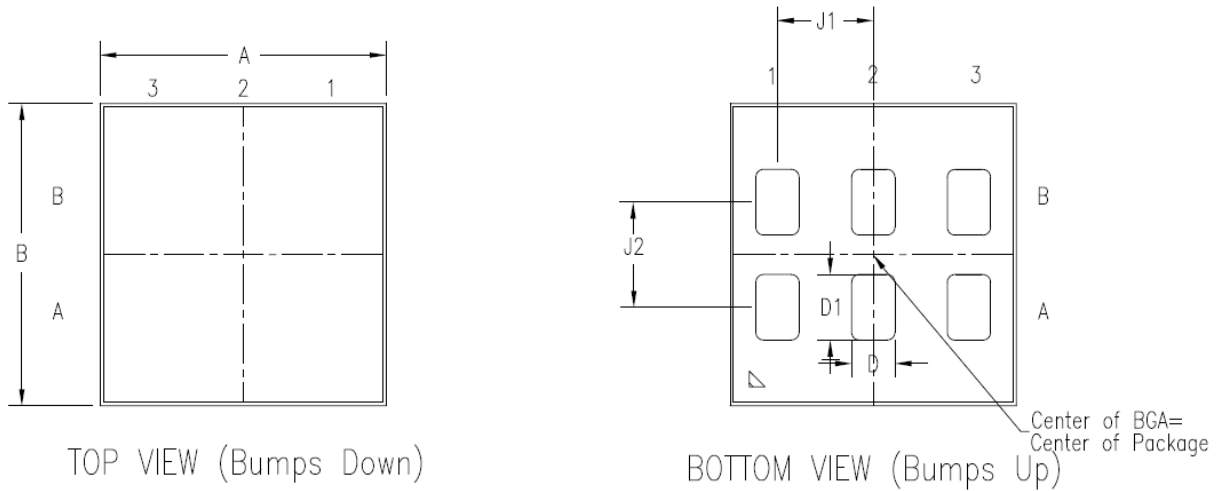

SYMBOL	PACKAGE DIMENSIONS		
	MIN	NOM	MAX
A	1065	1090	1115
B	1125	1150	1175
C	203	263	323
C1	5	10	15
C2	218	263	308
C3	125	145	165
D	135	165	195
D1	250	280	310
N	6 (INC)		
N1	3		
N2	2		
J1		365	
J2		400	

NOTE:

1. DIMENSIONS in μm .
2. The thickness of Bond-1 glass is 100 μm (green glass x 1pcs).
3. The material of solder printing is SAC305.

5. Part Order Information

Product Sales Code	Description	Package
ZOPT2202AC5R	ZOPT2202 LGA6 – Temperature range: -40 to +90°C	Reel
ZOPT2202AC9R	ZOPT2202 TSV – Temperature range: -40 to +90°C	Reel
ZOPT2202KIT V1.0	ZOPT2202 Evaluation Kit, including ZOPT Control Board, mini-USB cable, and 1 ZOPT2202 sample mounted on the LGA6 Sensor Board; kit software is available for free download – see the ZOPT Evaluation Kit Quick Start-up Guide included in the kit for instructions.	

6. Glossary

Term	Description
ADC	Analog-to-Digital Converter
LGA	Land-Grid Array (package type)
LS	Light Sensor (can be UVAS, UVBS, or UVB2S depending on ZOPT2202 configuration)
NVM	Non-volatile Memory
PWM	Pulse Width Modulation
SDA	Serial Data
SCL	Serial Clock
SW	Software
TVS	Through-Silicon Vias (package type)
UVA	Ultra violet energy in spectral range of 315nm to 400nm wavelength
UVB	Ultra violet energy in spectral range of 280nm to 315nm wavelength

7. Document Revision History

Release Date	Description
September 21, 2016	<ul style="list-style-type: none"> ▪ Added new package type TSV and its package information (see new section 4.2). ▪ Update for part codes. ▪ Addition of note about trimming factors for the UVAB_Raw Mode in Table 3.3. ▪ Addition of Table 3.1 for LGA pin descriptions and Table 3.2 for TVS package. ▪ Updates for Table 3.5 and Table 3.6. ▪ Updates for Figure 3.3 and Figure 3.4. ▪ Update for section 3.10.3 ▪ Added new section 4.1.3 for the reflow profile. ▪ Added new section 4.1.4 for tape packaging information. ▪ Minor edits for clarity and formatting.
April 20, 2016	Rebranding for IDT. Revision number is replaced with release date.
January 6, 2016 (Revision 1.00)	First release.

IMPORTANT NOTICE AND DISCLAIMER

RENESAS ELECTRONICS CORPORATION AND ITS SUBSIDIARIES (“RENESAS”) PROVIDES TECHNICAL SPECIFICATIONS AND RELIABILITY DATA (INCLUDING DATASHEETS), DESIGN RESOURCES (INCLUDING REFERENCE DESIGNS), APPLICATION OR OTHER DESIGN ADVICE, WEB TOOLS, SAFETY INFORMATION, AND OTHER RESOURCES “AS IS” AND WITH ALL FAULTS, AND DISCLAIMS ALL WARRANTIES, EXPRESS OR IMPLIED, INCLUDING, WITHOUT LIMITATION, ANY IMPLIED WARRANTIES OF MERCHANTABILITY, FITNESS FOR A PARTICULAR PURPOSE, OR NON-INFRINGEMENT OF THIRD PARTY INTELLECTUAL PROPERTY RIGHTS.

These resources are intended for developers skilled in the art designing with Renesas products. You are solely responsible for (1) selecting the appropriate products for your application, (2) designing, validating, and testing your application, and (3) ensuring your application meets applicable standards, and any other safety, security, or other requirements. These resources are subject to change without notice. Renesas grants you permission to use these resources only for development of an application that uses Renesas products. Other reproduction or use of these resources is strictly prohibited. No license is granted to any other Renesas intellectual property or to any third party intellectual property. Renesas disclaims responsibility for, and you will fully indemnify Renesas and its representatives against, any claims, damages, costs, losses, or liabilities arising out of your use of these resources. Renesas' products are provided only subject to Renesas' Terms and Conditions of Sale or other applicable terms agreed to in writing. No use of any Renesas resources expands or otherwise alters any applicable warranties or warranty disclaimers for these products.

(Rev.1.0 Mar 2020)

Corporate Headquarters

TOYOSU FORESIA, 3-2-24 Toyosu,
Koto-ku, Tokyo 135-0061, Japan
www.renesas.com

Contact Information

For further information on a product, technology, the most up-to-date version of a document, or your nearest sales office, please visit:
www.renesas.com/contact/

Trademarks

Renesas and the Renesas logo are trademarks of Renesas Electronics Corporation. All trademarks and registered trademarks are the property of their respective owners.

Mouser Electronics

Authorized Distributor

Click to View Pricing, Inventory, Delivery & Lifecycle Information:

[Renesas Electronics:](#)

[ZOPT2202AC6R](#)