

NOTES:

1. MATERIAL:
 - 1.1 HOUSING: THERMOPLASTIC, HIGH TEMP, UL94V-0, COLOR: BLACK.
 - 1.2 CONTACTS: COPPER ALLOY.
 - 1.3 HOLDDOWN: COPPER ALLOY.
2. FINISH:
 - 2.1 CONTACT:
 - SELECTIVE GOLD PLATING ON CONTACT AREA.
 - 100μ" MIN. MATTE-TIN PLATING ON SOLDERTAILS,
 - 50μ" MIN. NICKEL UNDERPLATING OVERALL.
 - 2.2 HOLDDOWN:
 - 100μ" MIN. MATTE-TIN PLATING WITH 50μ" MIN. NICKEL UNDERPLATE OVERALL.

PART NO.

91611 - X 1 X X X X XX

- Ridge Options
 - 0: Non Ridge
 - 1: With Ridge
- HSG Color
 - 1: Black
- Post Options
 - 0: With Post
 - 1: Without Post
- Contact Plating
 - 0: 30u" Gold
 - 1: 15u" Gold
 - 2: Gold Flash
- Halogen Options
 - BLANK: Halogen
 - HF: Halogen Free
- Packing Options
 - T: Tray Without Cap
 - C: Tray With Cap
 - R: Tape & Reel Packaging Without Cap
 - P: Tape & Reel Packaging With Cap
- No. of Pins
 - 0: 36P
 - 1: 64P
 - 2: 98P
 - 3: 164P

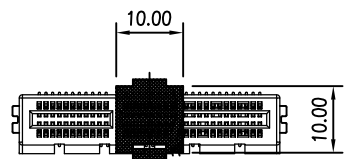
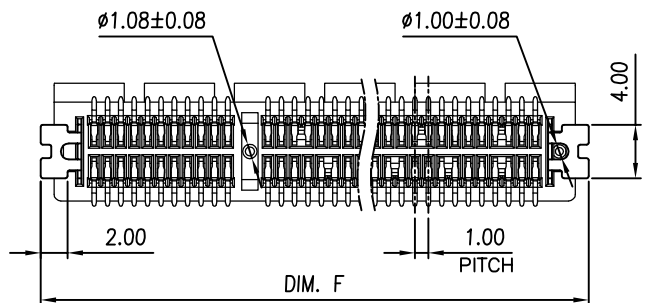
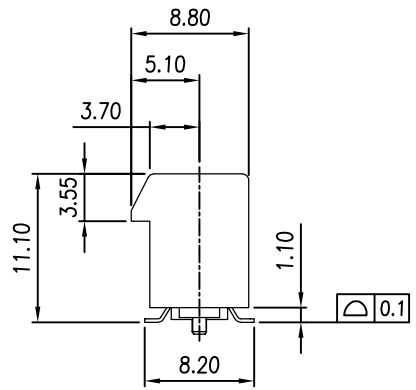
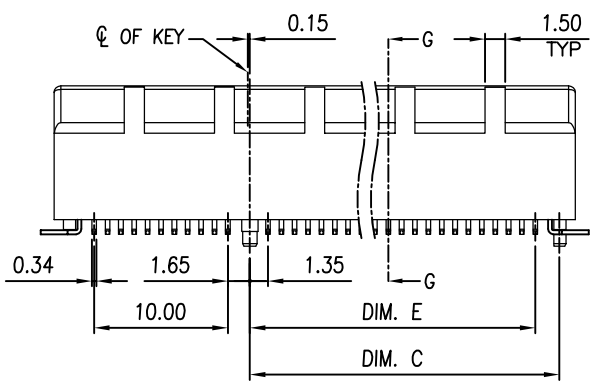

WITH CAP

DIMENSIONS						
POSITION	A ±0.20	B ^{+0.20} / _{-0.08}	C ±0.25	D ±0.25	E ±0.25	F ±0.25
36	6	7.65	9.15	25	7.35	27
64	20	21.65	23.15	39	21.35	41
98	37	38.65	40.15	56	38.35	58
164	70	71.65	73.15	89	71.35	91

REV	ECN NO.	NAME	DATE	TOLERANCE	
				LINEAR	ANGLES
2	---	Schumi	Jun,14,2019	X.±0.40	X'±
1	---	Lei Songping	Mar,18,2019	.X±0.30	.X'±
0	---	Schumi	Aug,02,2018	.XX±0.20	.XX'±
---	---	---	---	.XXX±0.10	.XXX'±

UMax conn 东莞市友贸实业有限公司
DONGGUAN UMAXCONN ENTERPRISE LIMITED

APPD: Jason MAT'L:
CHKD: Schumi FINISH:
DRWN: Lei Songping Q'TY:

TITLE: PCI EXPRESS 4.0 SMT TYPE

PART NO. 91611-X1XXXXXX

DWG NO. C-91611

UNITS	SCALE	SHEET	REV
MM	1 : 1	1 OF 2	2

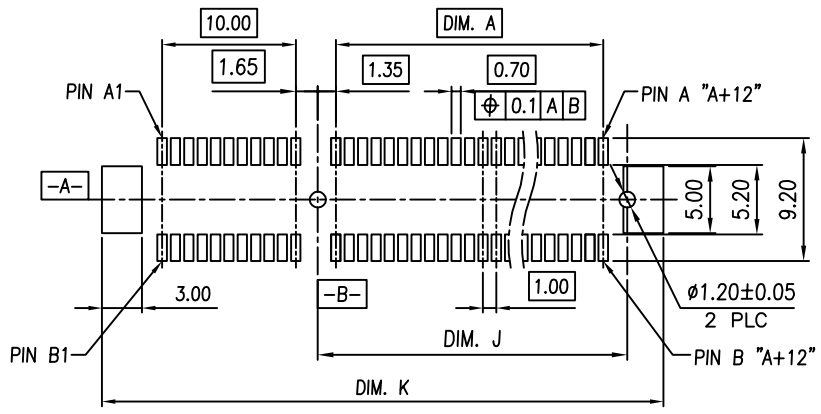
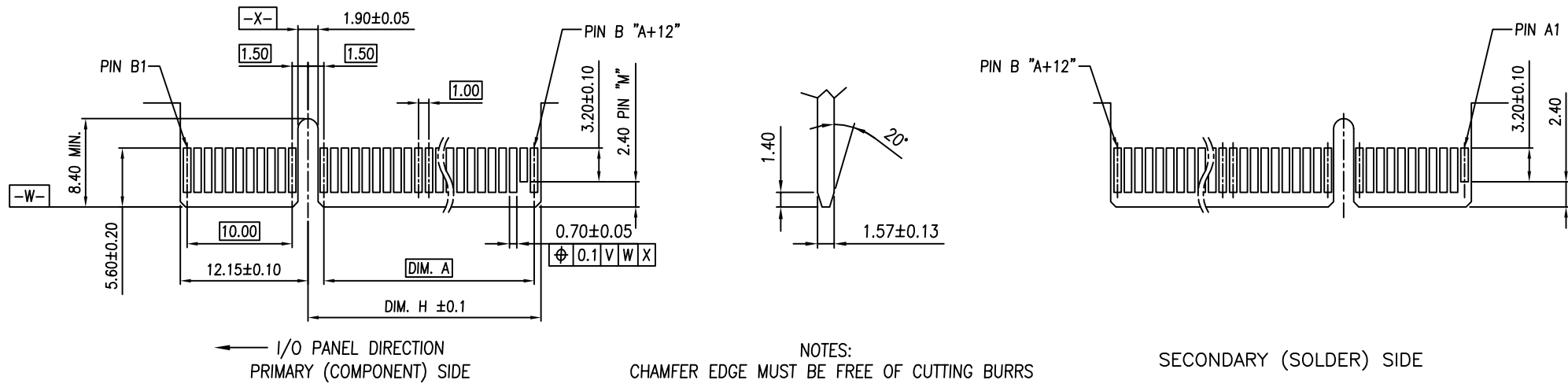

RECOMMENDED PCB LAYOUT
(COMPONENT SIDE)

TOLERANCE: ±0.05

POS.	DIM. A	DIM. H	DIM. J	DIM. K	"M"
36	6	8.15	9.15	28.0	B17
64	20	22.15	23.15	42.0	B31
98	37	39.15	40.15	59.0	B48
164	70	72.15	73.15	92.0	B81

TOLERANCE		UMax conn DONGGUAN UMAXCONN ENTERPRISE LIMITED	TITLE: PCI EXPRESS 4.0 SMT TYPE	
LINEAR	ANGLES		PART NO.	91611-X1XXXXXX
X.±	X'.±	APPD: Jason	MAT'L:	DWG NO. C-91611
.X±	.X'±	CHKD: Schumi	FINISH:	
.XX±	.XX'±	DRWN: Lei Songping	Q'TY:	
.XXX±	.XXX'±			UNITS: MM
				SCALE: 1 : 1
				SHEET: 2 OF 2
				REV: 2

See Sheet 1			
REV	ECN NO.	NAME	DATE