

				TOLERANCE		UMax conn 东莞市友贸实业有限公司 DONGGUAN UMAXCONN ENTERPRISE LIMITED		TITLE: MINI PCI EXPRESS 6.8MM HEIGHT			
				LINEAR	ANGLES			PART NO. 91304-68-052RXXX			
				X±0.40	X'±	APPD: Jason	MAT'L:	DWG NO. C-91304-68			
				.X±0.30	.X'±	CHKD: Schumi	FINISH:	UNITS	SCALE	SHEET	REV
0	----	Lei Songping	Jun,06,2019	.XX±0.20	.XX'±	DRWN: Lei Songping	Q'TY:	MM	1 : 1	1 OF 5	0
REV	ECN NO.	NAME	DATE	.XXX±0.15	.XXX'±						

NOTES:

1. MATERIAL:
 HOUSING: THERMOPLASTIC, HIGH TEMP, UL94V-0, BLACK COLOR,
 CONTACTS: COPPER ALLOY.
 PEGS: COPPER ALLOY.

2. FINISH:
 CONTACTS: SELECTED GOLD PLATING ON THE CONTACT AREA,
 1u" MIN. GOLD PLATING ON THE SOLDER TAILS,
 50 u" MIN. NICKEL UNDERPLATING OVER ALL.
 PEGS: 120u" MIN. MATTE-TIN OVER 50u" MIN. NICKEL.

3. PACKAGING SPECIFICATION: 9130404001

4. PRODUCT SPECIFICATION: PS-MINI PCI-E-01

5. DATE CODE.

YYWWDD

YY: YEAR (19: 2019)

WW: WEEK (25: THE 25TH WEEK)

DD: (D1~D7: SUNDAY~SATURDAY)

PRODUCT NUMBER CODE

91304 - 68 - 052 R X XX

68: 6.8H HEIGHT

52 CONTACTS

PACKAGING OPTIONS
 R: TAPE & REEL

HALOGEN OPTIONS
 BLANK: HALOGEN
 HF: HALOGEN FREE

CONTACT AREA PLATING
 0: 30u" GOLD
 1: 10u" GOLD
 2: GOLD FLASH

				TOLERANCE		UMax 东莞市友贸实业有限公司 conn DONGGUAN UMAXCONN ENTERPRISE LIMITED		TITLE: MINI PCI EXPRESS 6.8MM HEIGHT				
				LINEAR	ANGLES			PART NO. 91304-68-052RXXX				
				X.±0.40	X'±	APPD: Jason	MAT'L:	DWG NO. C-91304-68				
				.X±0.30	.X'±	CHKD: Schumi	FINISH:		UNITS	SCALE	SHEET	REV
0	-----	Lei Songping	Jun,06,2019	.XX±0.20	.XX'±	DRWN: Lei Songping	Q'TY:		MM	1 : 1	2 OF 5	0
REV	ECN NO.	NAME	DATE	.XXX±0.15	.XXX'±							

COMPONENT KEEP OUT AREA FOR
CARD HOLD DOWN SOLUTION

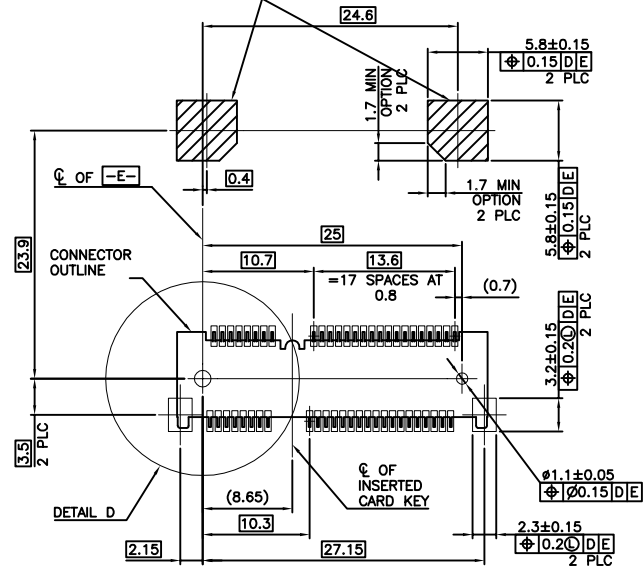

-D- IS THE TOP SURFACE OF PCB.
RECOMMENDED P.C. BOARD PATTERN LAYOUT
FOR HALF CARD CONNECTOR
(TOP VIEW)

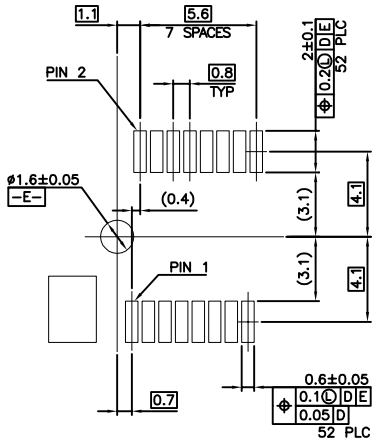
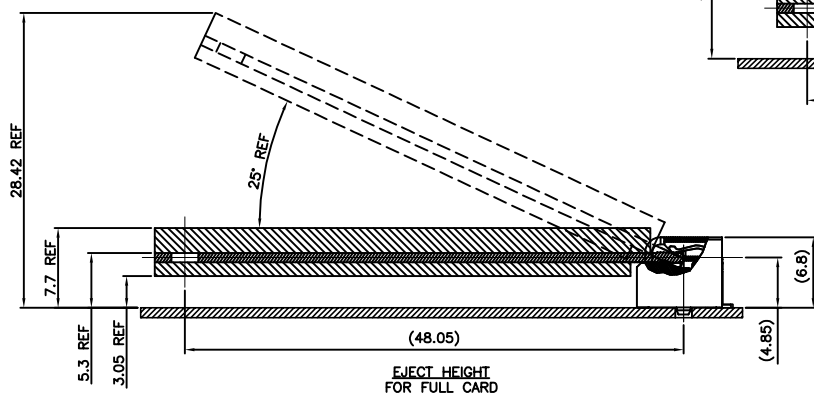

DETAIL D
SCALE 2:1

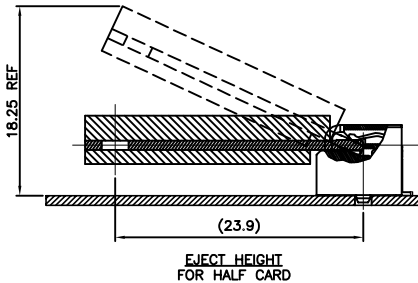

COMPONENT KEEP OUT AREA FOR
CARD HOLD DOWN SOLUTION

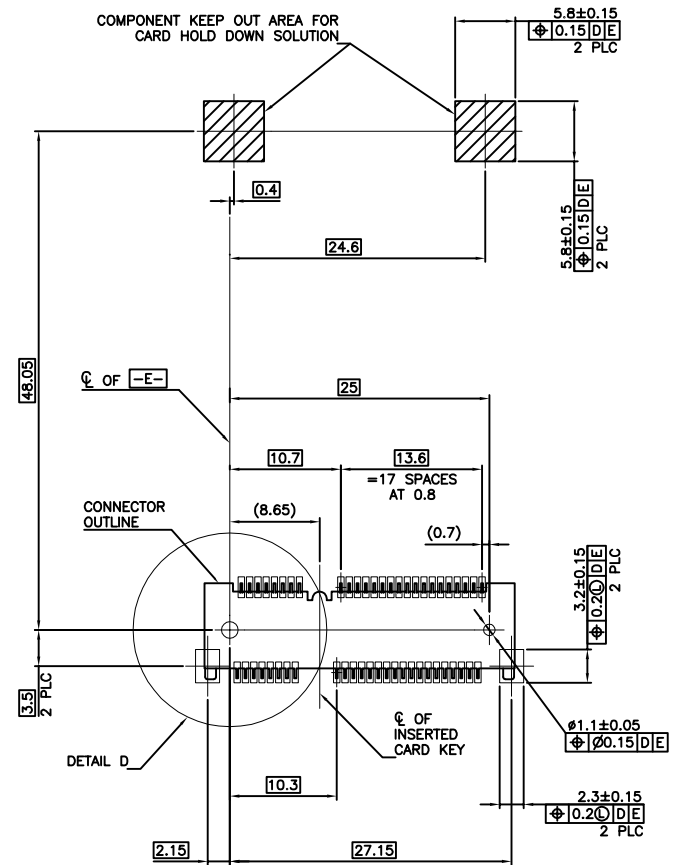

-D- IS THE TOP SURFACE OF PCB.
RECOMMENDED P.C. BOARD PATTERN LAYOUT
FOR FULL CARD CONNECTOR
(TOP VIEW)

0	----	Lei Songping	Jun,06,2019	.XX±	.XX'±
REV	ECN NO.	NAME	DATE	.XXX±	.XXX'±

TOLERANCE	
LINEAR	ANGLES
X.±	X'.±
.X±	.X'±
.XX±	.XX'±
.XXX±	.XXX'±

UMax 东莞市友贸实业有限公司
conn DONGGUAN UMAXCONN ENTERPRISE LIMITED

APPD: Jason
CHKD: Schumi
DRWN: Lei Songping

MAT'L:
FINISH:
Q'TY:

TITLE: MINI PCI EXPRESS 6.8MM HEIGHT

PART NO. 91304-68-052RXXX

DWG NO. C-91304-68

	UNITS	SCALE	SHEET	REV
	MM	1 : 1	3 OF 5	0

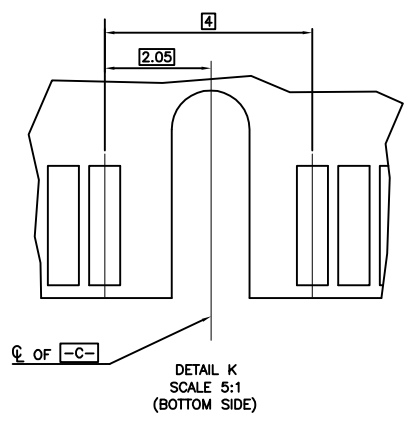
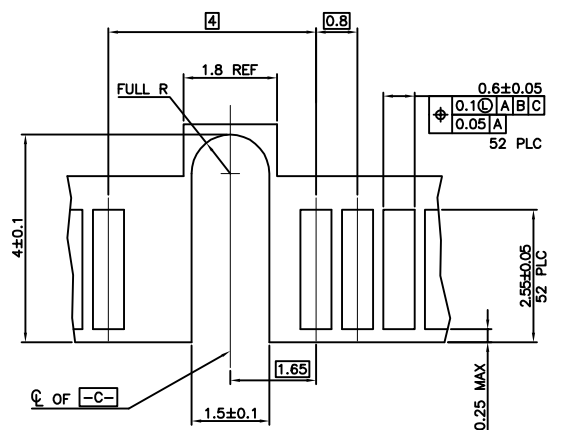
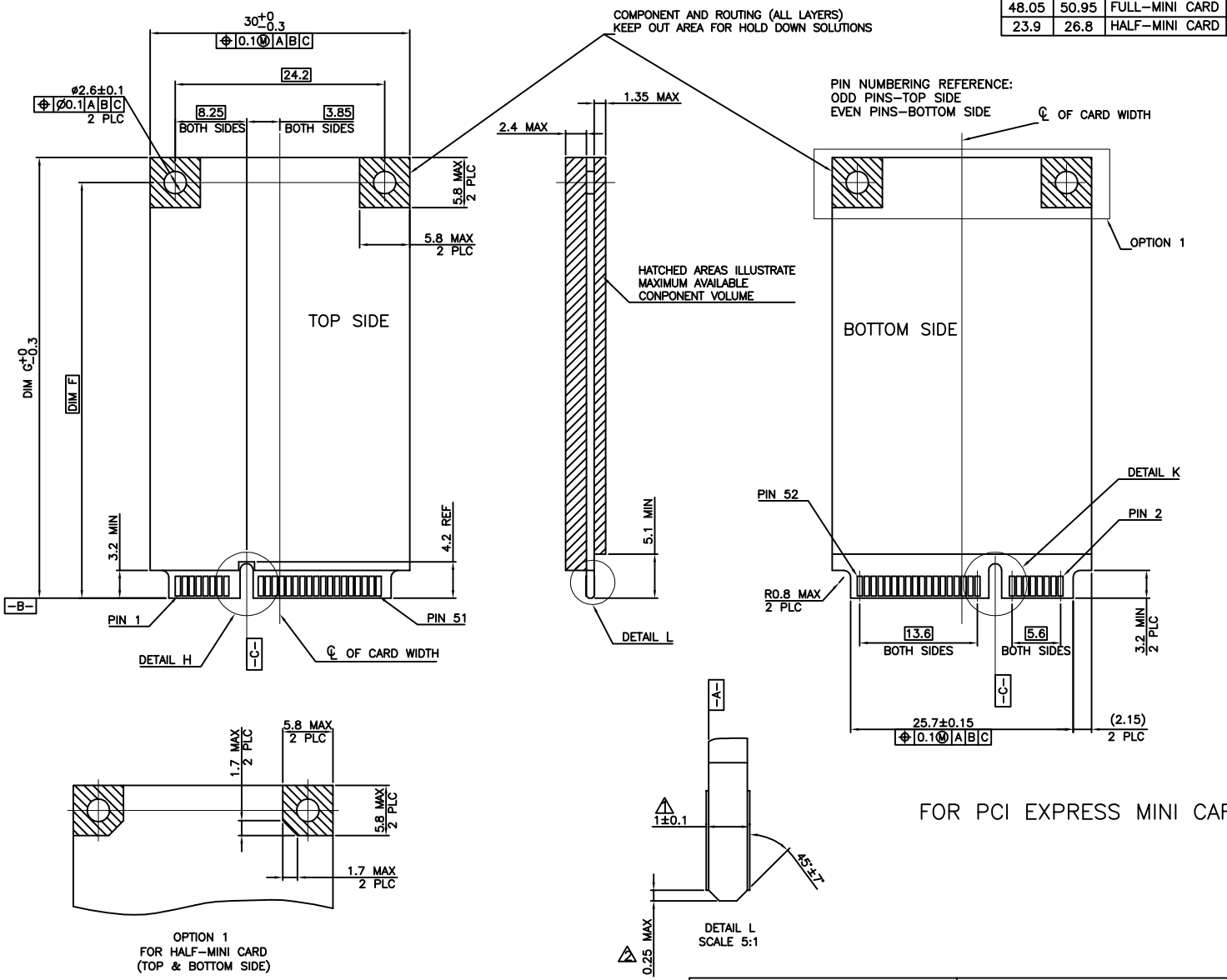

NOTES:
 ▲ CARD THICKNESS APPLIES ACROSS TABS AND INCLUDES PLATING AND/OR METALLIZATION.
 ▲ EDGE BEVEL MUST BE PRESENT AND FREE OF CUTTING BURRS FROM PCB AND CONTACT MATERIALS.

FOR PCI EXPRESS MINI CARD

OPTION 1 FOR HALF-MINI CARD (TOP & BOTTOM SIDE)

TOLERANCE	
LINEAR	ANGLES
X.±	X'.±
.X±	.X'±
0	----
REV	.XXX±

UMax conn 东莞市友贸实业有限公司 DONGGUAN UMAXCONN ENTERPRISE LIMITED	
APPD: Jason	MAT'L:
CHKD: Schumi	FINISH:
DRWN: Lei Songping	Q'TY:

TITLE: MINI PCI EXPRESS 6.8MM HEIGHT			
PART NO. 91304-68-052RXXX			
DWG NO. C-91304-68			
UNITS	SCALE	SHEET	REV
MM	1 : 1	4 OF 5	0

REV	ECN NO.	NAME	DATE
0	----	Lei Songping	Jun,06,2019

CUSTOMER

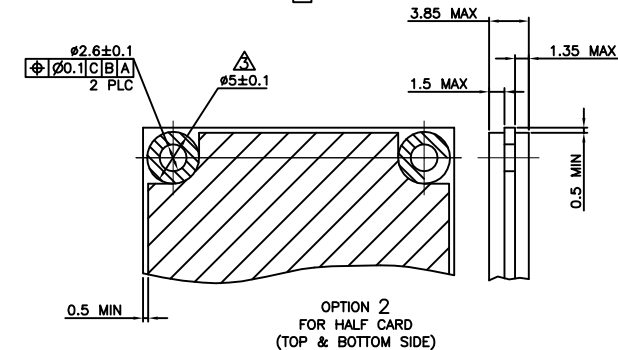
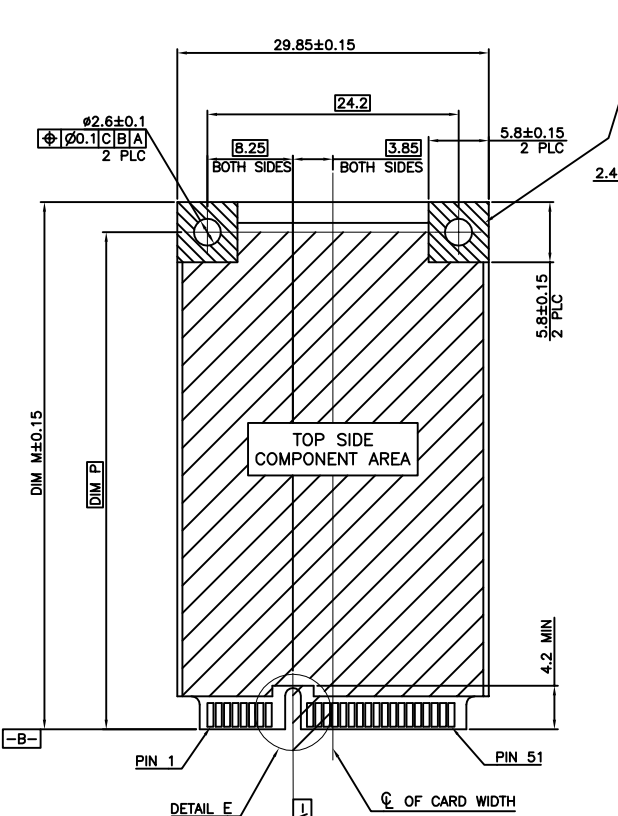

COMPONENT AND ROUTING (ALL LAYERS)
KEEP OUT AREA FOR HOLD DOWN SOLUTIONS

DIM P	DIM M	
48.05	50.8	FULL CARD
23.9	26.8	HALF CARD

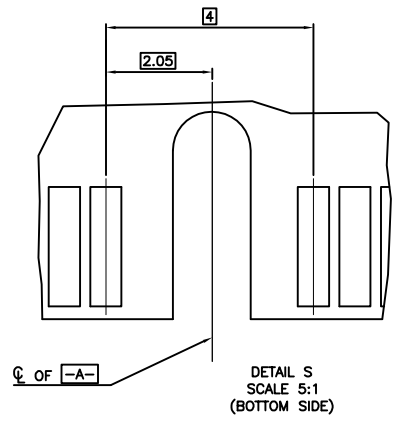
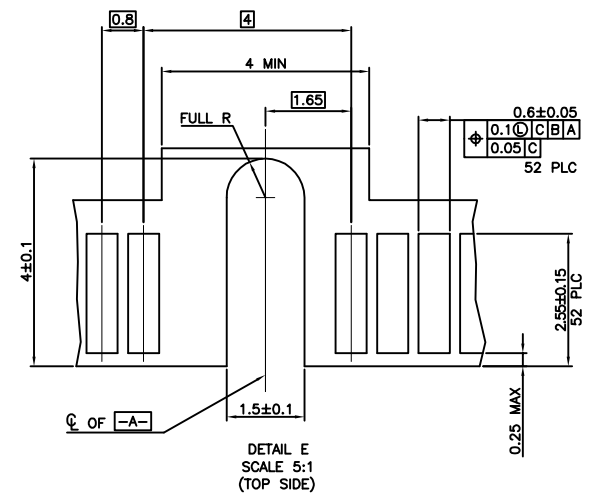
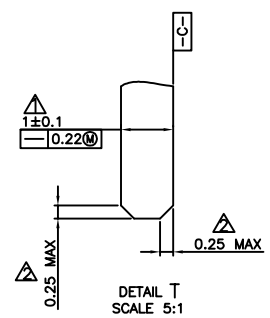
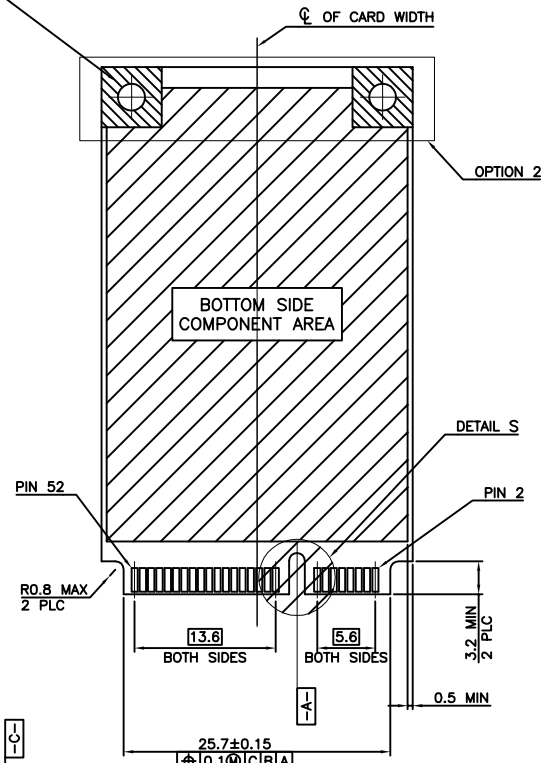
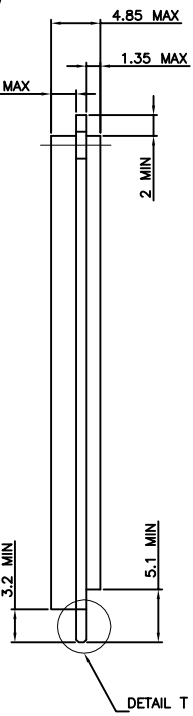

- NOTES:
- △ CARD THICKNESS APPLIES ACROSS TABS AND INCLUDES PLATING AND/OR METALLIZATION.
 - △ EDGE BEVEL MUST BE PRESENT AND FREE OF CUTTING BURRS FROM PCB AND CONTACT MATERIALS.
 - △ COMPONENT AND ROUTING (TOP/BOTTOM LAYER) KEEP OUT AREA FOR HOLD DOWN SOLUTIONS.

REV	ECN NO.	NAME	DATE	TOLERANCE	
				LINEAR	ANGLES
0	----	Lei Songping	Jun,06,2019	.XX±	.XX°±
REV	ECN NO.	NAME	DATE	.XXX±	.XXX°±

UMax conn 东莞市友贸实业有限公司
DONGGUAN UMAXCONN ENTERPRISE LIMITED

APPD: Jason MAT'L:

CHKD: Schumi FINISH:

DRWN: Lei Songping Q'TY:

TITLE: MINI PCI EXPRESS 6.8MM HEIGHT

PART NO. 91304-68-052RXXX

DWG NO. C-91304-68

UNITS	SCALE	SHEET	REV
MM	1 : 1	5 OF 5	0